

GOVERNMENT NOTICE NO. 229 published on 5/08/2016

THE WEIGHTS AND MEASURES ACT

(CAP.340)

**REGULATIONS**

*(Made under Section 54)*

THE WEIGHTS AND MEASURES (GENERAL) REGULATIONS, 2016

ARRANGEMENT OF REGULATIONS

*Regulation*

*Title*

PART I

PRELIMINARY PROVISIONS

1. Short title.
2. Interpretation.

PART II

CARE AND CUSTODY OF STANDARDS

3. Verification of Secondary standards.
4. Verification mark.

PART III

VERIFICATION OF WEIGHTS, MEASURES AND INSTRUMENTS

5. Verification of working standards
6. Stamp of obliteration
7. Examination on dealers' premises
8. Duties of a person who submits weight, measure or instrument

*G.N. No. 229 (contd.)*

9. Weights, etc., to be clean
10. Testing procedure
11. Testing facilities for approval of patterns
12. Sealing, breaking a seal and re-sealing
13. Use of liquid fuel, etc
14. Admittance of weights, measures weighing and pricing instruments
15. Abbreviations
16. Prescribed Form

PART IV  
WEIGHTS

17. Materials for weights
18. Denomination of weights
19. Flaws
20. Mode of adjusting weights
21. Shape of weights
22. Permissible errors
23. Mode of stamping or certifying weights

PART V  
MEASURES OF LENGTH

24. Material of length
25. Denomination
26. Tension for linked and tape measures
27. Permissible errors
28. Position of stamping

PART VI  
MEASURES OF CAPACITY

29. Material and construction
30. Lips or retaining edges
31. False bottom
32. Publican's measure
33. Dipping measures
34. Taps
35. Glass measures
36. Earthenware
37. Temperature compensators

*G.N. No. 229 (contd.)*

- 38. Subdivided metal measures
- 39. Denomination
- 40. Apothecaries measures
- 41. Method of testing
- 42. Meniscus
- 43. Permissible errors
- 44. Method of stamping

PART VII  
WEIGHING INSTRUMENTS

- 45. Conditions for structure of weighing instruments
- 46. Marking of weighing capacity
- 47. Materials of Construction
- 48. Graduations
- 49. Plug for verification stamp
- 50. Loose counterpoise and travelling poise
- 51. Special trades
- 52. Position when testing
- 53. Test at maximum load and tests for sensitiveness
- 54. Tests for error
- 55. Balanced Instrument
- 56. Weighing range

PART VIII  
ELECTRONIC MEASURING INSTRUMENTS

- 57. Registration
- 58. Special requirements
- 59. Zero tracking mechanism
- 60. Leveling
- 61. Tare devices
- 62. Contrast
- 63. Record of registration
- 64. Starting position
- 65. Means of indication
- 66. Marking
- 67. Indicator
- 68. Repeatability
- 69. Installation and use
- 70. Location of primary indicator
- 71. Multi-interval instrument

*G.N. No. 229 (contd.)*

- 72. Permissible errors
- 73. Manner of sealing

PART IX  
BEAM SCALES

- 74. Classification
- 75. Prohibition of certain types
- 76. Balancing mechanism
- 77. Half-load test
- 78. Position of loading
- 79. Permissible errors
- 80. Position of stamping

PART X  
COUNTER MACHINES

- 81. Construction of counter machines
- 82. Prohibition of certain types
- 83. Fall on counter machines
- 84. Lateral movement test
- 85. Position of weights during test
- 86. Method of testing
- 87. Counter machines with scoops
- 88. Permissible errors
- 89. Stamping

PART XI  
SPRING BALANCES

- 90. Suspension
- 91. Width of index finger
- 92. Dimensions of graduations
- 93. Range of adjustable indicator
- 94. Interval between graduations
- 95. Position of the weight during test
- 96. Testing of graduations
- 97. Fatigue test
- 98. Permissible errors
- 99. Testing for sensitivity
- 100. Position of stamping

PART XII  
DEAD-WEIGHT MACHINES

- 101. Construction
- 102. Balancing
- 103. Permissible errors
- 104. Position of stamping plug

PART XIII  
PLATFORM MACHINES AND WEIGHBRIDGES

- 105. Test in situ
- 106. Foundations
- 107. Construction
- 108. Travel
- 109. Counterpoises
- 110. Balancing
- 111. Gravity balls
- 112. Self-indicating machines
- 113. Mode of testing
- 114. Test at quarter load
- 115. Relieving gear
- 116. Permissible errors
- 117. Position of stamping plug

PART XIV  
CRANE MACHINES

- 118. Construction
- 119. Balancing
- 120. Mode of testing
- 121. Permissible errors
- 122. Position of stamping plug

PART XV  
AUTOMATIC MACHINES

- 123. Adjusting mechanism
- 124. Mode of testing
- 125. Totalizing machines
- 126. Permissible errors
- 127. Certification

PART XVI  
SELF-INDICATING WEIGHING INSTRUMENTS

- 128. Graduations
- 129. Pointer
- 130. Value of graduation
- 131. Mode of testing
- 132. Permissible errors
- 133. Position of stamping

PART XVII  
VEHICLE TANKS

- 134. Construction and design
- 135. Construction quantity indicators, piping, gauges and valves
- 136. Complete delivery required
- 137. Ventilation and filler openings
- 138. Position of indicator
- 139. Design and sealing of indicators
- 140. Gauges to be identified with compartments
- 141. Provision for expansion
- 142. Method of testing
- 143. Charts of gauges
- 144. Emergency valves
- 145. Permissible error
- 146. Construction licensing
- 147. Validity of licence
- 148. Cancellation of the licence
- 149. Appeal to the Minister
- 150. Prohibition of constructing of vehicles or tanks
- 151. Penalty

PART XVIII  
LIQUID MEASURING PUMPS

- 152. Prohibition of certain types
- 153. Measuring pump
- 154. Denomination
- 155. Prohibition of certain markings
- 156. Sales indicators
- 157. Marking of graduations

*G.N. No. 229 (contd.)*

- 158. Discharge signals
- 159. Swing arms, flexible pipes and nozzles
- 160. Sight glasses
- 161. Test under working conditions
- 162. Testing a liquid measuring instrument
- 163. Permissible errors
- 164. Test by the owner or user
- 165. Mode of Filling Measures of Capacity
- 166. Provision of seals and sticker.

PART XIX

WEIGHTS, MEASURES AND INSTRUMENTS OF THE METRIC SYSTEM

- 167. Permissible errors
- 168. Marking
- 169. Weights

PART XX  
INSPECTION

- 170. Visiting trade premises
- 171. Obliteration of stamp

PART XXI

REPAIR OR MANUFACTURE OF MEASURING INSTRUMENTS OR  
SYSTEMS

- 172. Repairer and manufacturer to be licensed
- 173. Types of licenses and forms
- 174. Duration of licence and fees
- 175. Cancellation of licence
- 176. Licence to be displayed
- 177. Where instruments or system may be repair
- 178. Licensee to issue form
- 179. A licensee to maintain register
- 180. Duty of licensee to submit documents, measuring instruments or system for inspection or verification
- 181. Verification of test weights and measures
- 182. Charges for verifications and adjusting fees

PART XXII

*G.N. No. 229 (contd.)*

PRE-PACKED GOODS INSPECTIONS, TESTING AND CERTIFICATION  
FEES

- 183. Mode of labeling
- 184. Powers to test and certify
- 185. Government fees and certification
- 186. Cancellation of a certificate of conformity
- 187. Rejection Note

PART XXIII  
GENERAL PROVISIONS

- 188. Offence in relation to installment
- 189. General Offence
- 190. Repeal of G.N.No 339 of 1960 and G.N.NO 415 of 2012
- 191. Savings



—  
SCHEDULES  
—

THE WEIGHTS AND MEASURES ACT

(CAP 340)

—  
**REGULATIONS**  
—

*(Made under Section 54)*

THE WEIGHTS AND MEASURES (GENERAL) REGULATIONS, 2016

PART I

PRELIMINARY PROVISIONS

- Short title                    1. These Regulations may be cited as the Weights and Measures (General) Regulations, 2016.
- Interpretation                2. In these Regulations, unless the context requires otherwise –
- Cap.340                        “Act” means the Weights and Measures Act;  
                                      “assizer” means a Weights and Measure Officer appointed under section 14 of the Act;  
                                      “automatic machine” means a measuring instrument in which a self-acting machinery carries out an automatic feed of the measure and which does not require an operator to carry out the measuring process;  
                                      "beam scale" means any equal-armed weighing instrument the pans of which are below the beam either suspended without an arrestment device or otherwise supported with or without an arrestment device;  
                                      “calibration” means the set of operations that establish under specified conditions, the relationship between values

*G.N. No. 229 (contd.)*

- indicated by a measuring instrument, a measuring system or values represented by a material measure, and the corresponding known values of measure; and;
- “calibration chart” means the expression of the mathematical function  $V(h)$ , in the form of a chart, which represents the relation between the height "h" (independent variable) and volume "V" (dependent variable);
- “capacity” in relation to a weighing instrument, means the maximum load which that instrument is constructed to weigh, as marked or indicated on the instrument;
- “compartment” in relation to a subdivided rail or road tank, means any subdivided portions of the tank;
- “counter machine” means an equal-arm weighing instrument of which the pans are above the beam and of a capacity of not more than 50kg;
- “crane machine” means a suspended self-indicating, electronic, hydraulic or spring actuated weighing machine of a capacity of 1000 kg or above;
- “dead-weight machine” means any weighing instrument, similar in principle of construction, to a counter machine of a capacity of more than 50 kg;
- “electronic instrument” means an instrument that operates with electronic components and is equipped with a digital means of indication;
- “flow meter” means an instrument for measuring liquid that indicates automatically the volume of liquid that has flowed through it;
- “initial verification” means verification of a new or a previously unverified measuring instrument in accordance with approved type or metrological requirements prior to its placement on the market or putting into service;
- “instrument” means any weighing or measuring instrument;
- “just” means any weight, measure, weighing or measuring instrument which does not have an error greater than the limit of error as set out in the Third Schedule to these Regulations;
- “liquid measuring pump” means any measuring instrument for the measurement of liquid fuel or lubricating oils for sale in individual quantities and includes a fuel dispensing pump;
- “multi-interval device” means a device having one weighing

range divided into partial weighing ranges each with different scale intervals, with the weighing range determined automatically according to the load applied (pre-determined ranges or intervals), both on increasing and decreasing load;

“multiple range scale” means a weighing instrument having two or more weighing ranges with different maximum capacities and different scale intervals for the same load receptor, each range extending from zero to its maximum capacity and the selection of the weighing range may be determined manually through a pushbutton or switch or may automatically change to the higher capacity range once the load exceeds the capacity of the lower range;

“nominal capacity” means the volume of liquid which a tank contains under rated operations, at a reference temperature and as indicated on the tank or compartment;

“rail or road tank” means a container which may be subdivided into two or more compartments, mounted on a wagon or motor truck and used for the sale or delivery by measures of capacity of paraffin, fuel, oil, petrol, or petrol substitutes;

“reference height (H)” means the distance, measured along the vertical measurement axis, between the reference point and the foot of the vertical measurement axis, on the inner surface of the tank, or on the dip plate;

“rejected” in relation to a weight, measure or instrument means any weight, measure or instrument examined by an assizer and found not to comply with the requirements of the Act;

“repaired” in relation to a weight, measure or instrument means any weight, measure or instrument which since it was last stamped has had some adjustment, other than balancing in the case of a weighing instrument, made to any of its vital parts;

“self-indicating weighing instrument” means a weighing instrument on which the whole or part of the weight of the goods being weighed is indicated by a pointer moving over a scale or chart graduated in units of mass, or a graduated chart moving in relation to a fixed pointer, or digital display, or by means of a printed record;

“sensitivity of a tank in the vicinity of a filling level h” means the change in the level,  $\Delta h$ , divided by the corresponding

*G.N. No. 229 (contd.)*

- relative change in volume,  $h/v$  for the contained volume corresponding to the level;
- “spring balance” means a mechanical weighing instrument in which the weight is determined by the extensions or compression of a spring, such extension or compression being indicated by a pointer on a dial or by a moving graduated scale;
- “stamp of verification” means a stamp which bears a verification mark;
- “subsequent verification” means a periodic verification of a measuring instrument after the previous verification, as well as the verification of the measuring instrument after repair;
- “total contents” means the maximum volume of liquid which a tank may contain with underrated operating conditions at reference temperature;
- “ullage height (C)” means the distance between the free surface of the liquid and the reference point, measured along the vertical measurement axis;
- “vehicle tank” means a container comprising of necessary piping, valves and or meters which may be subdivided into two or more compartments mounted on a wagon, motor vehicle or any other assembly used for measurements and delivery of fluids;
- “verification” means examination testing, passing as fit for use for trade and stamping any weight, measure, weighing or measuring instrument;
- “verification mark” is a mark which bears the coat of arms of the United Republic of Tanzania, month and the year of verification and if applicable it may bear the identification of verifying officer;
- “verification station” means any place where the possessors or users of instruments are required to submit the instruments for verification pursuant to section 19(1) of the Act;
- “verification sticker” means an adhesive label that bears the verification mark;
- “vertical measurement axis” means the vertical line on which the levels of liquid are gauged;
- “weighing instrument” means a measuring instrument that uses the action of gravity on a body to determine the weight of the body

PART II

CARE AND CUSTODY OF STANDARDS

Verification  
of Secondary  
Standards

3.-(1) The accuracy of the secondary standards shall be verified at least once in every two years by comparing such standards with the National standards.

(2) The Commissioner shall, for the purposes of verifying the accuracy of secondary standards, submit the secondary standards to the Tanzania Bureau of Standards for calibration.

(3) Tanzania Bureau of Standards shall, after calibrating secondary standards against National Standards, issue the Certificate of Calibration to the Commissioner.

(4) The Commissioner shall, after receiving the Certificate issued under sub regulation (3), the prescribed Form, set out in the First Schedule to these Regulations.

Verification  
mark

4.-(1) An assizer shall verify the accuracy of the working standards at least once in every twelve months by comparing the standards with the secondary standards.

(2) The Commissioner shall, where the assizer has verified working standards, authenticate the standards by issuing a certificate of verification in the prescribed Form B set out in the First Schedule to these Regulations.

PART III

VERIFICATION OF WEIGHTS, MEASURES AND INSTRUMENTS

Verification  
of working  
standards

5.-(1) An assizer shall stamp just weights, measures and instruments with either a stamp of verification or verification sticker which bears a verification mark.

(2) A verification mark shall contain-

(a) the Coat of arms of the United Republic of Tanzania as shown below:

G.N. No. 229 (contd.)

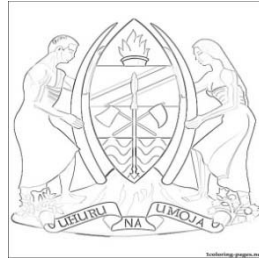

- (b) a letter indicating the month of verification in the following manner—
- (i) A for January;
  - (ii) B for February;
  - (iii) C for March;
  - (iv) D for April;
  - (v) E for May;
  - (vi) F for June;
  - (vii) G for July;
  - (viii) H for August;
  - (ix) I for September;
  - (x) J for October;
  - (xi) K for November; and
  - (xii) L for December.
- (c) the year of verification, which shall be indicated by the last two digits, thus the year 2015 shall be shown as "15".

Stamp of  
obliteration

6.-(1) The stamp of verification on a weight, measure or instrument shall be obliterated only by means of a stamp of the following six-pointed star design:

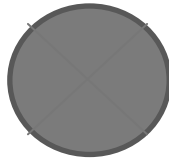

(2) Any weight measure or instrument bearing the obliteration in sub regulation (1) shall be deemed to be unstamped.

(3) Where any instrument is required to be stamped or sealed on more than one place, the obliteration of any one stamp or the breaking of any one seal or sealing device shall render the instrument unstamped.

*Weights and Measures (General) Regulations*

---

*G.N. No. 229 (contd.)*

Examination  
on dealers'  
premises

7. Weights, measures and instruments may be examined on the premises of a repairer or dealer upon request:

Provided that the travelling expenses of the assizer and the cost of transport of standards and equipment shall be paid by the repairer or dealer in addition to the prescribed verification fee.

Duties of a  
person who  
submits  
weight,  
measure or  
instrument

8. An assizer may require any person who submits any weight, measure or instrument for examination to-

- (a) disassemble it to such an extent as to enable him to examine the working parts; and
- (b) provide sufficient labour for the proper and expeditious handling of the standards or any material which is to be used in the testing of any such weight, measure or instrument.

Weights, etc.,  
to be clean

9.-(1) All weights, measures or instruments shall be in a clean condition before being presented to an assizer.

(2) Where the weights, measure or instrument is not clean, an assizer shall require the owner or user to clean such weights, measure or instrument.

(3) A person who fails to comply with sub regulation (2) shall, in addition to stamping fees, be charged a sum of money equal to the fees for stamping of any weight or measure of a similar denomination or capacity.

Testing  
procedure

10. An assizer shall, before stamping any weight, measure or instrument, ascertain if it complies with the requirements of the Act and these Regulations.

Testing  
facilities for  
approval of  
patterns

11.-(1) A weight, measure, weighing or measuring instrument shall be verified, stamped or authorised for use or trade unless it is of a:

- (a) pattern approved by the Minister; or
- (b) class or kind exempted from the provisions of these Regulations.

(2) The Minister shall, upon verification in sub regulation (1), issue a certificate of approval in a prescribed Form G as set out in the First Schedule to these Regulations.

*G.N. No. 229 (contd.)*

Sealing,  
breaking a  
seal and re-  
sealing

12. The Commissioner may authorise any qualified person in the erection, repair and adjustment the liquid measuring pumps in regulation 146, to break any seal or sealing device on the instrument and re-seal the same subject to the following conditions-

- (a) that the Commissioner may withdraw any such authorisation at any time;
- (b) that the person authorised be equipped with stamped testing measures of a pattern approved by an assizer and test each instrument for accuracy before sealing or re-sealing;
- (c) that the person authorised seals or re-seals an instrument only by means of stamping pliers so constructed as to impress upon every seal or sealing device such mark and number as the Commissioner may allot to him for the purpose of identification;
- (d) that the person authorised reports in writing to the assizer in Form D as set out in the First Schedule to these Regulations, within twenty four hours after sealing or re-sealing;
- (e) that the owner or user of the instrument sends an assizer a request in writing to verify the instrument, within twenty four hours of such sealing or re-sealing.

Use of liquid  
fuel, etc

13.-(1) An assizer may at any time withdraw any liquid fuel or lubricating oil from a measuring instrument for the purpose of testing such instrument.

(2) An assizer shall return to the tank or container any liquid, fuel or lubricating oil withdrawn pursuant to sub regulation (1) and furnish to the user or owner a written statement of the quantity withdrawn.

Admittance of  
weights,  
measures  
weighing and  
pricing  
instruments

14. An assizer shall not admit for verification any weight, measure, weighing instrument, measuring instrument or price computing instrument which-

- (a) is not complete;
- (b) bears any mark which might be mistaken for a stamp of verification;
- (c) is not sufficiently strong to withstand the ordinary wear and tear of use in trade;



*G.N. No. 229 (contd.)*

- (d) has removable parts, the removal of which would affect its accuracy unless the parts are such that the weight, measure or instrument cannot be used without them;
- (e) has reversible or interchangeable parts, the reversal or interchange of which would affect its accuracy unless such parts are clearly and indelibly marked to indicate their position; or
- (f) is not properly constructed, or when, in his opinion, it appears to be of a pattern which might facilitate the perpetration of fraud.

Abbreviations

15. The denomination of a weights, measures, or the capacity of an instrument, if not marked in full, shall be indicated by one of the abbreviations specified in the Act.

Prescribed Form

16. In exercise of the powers vested in him by section 35(2) of the Act, the Commissioner shall use Form C as set out in the First Schedule to these Regulations.

#### PART IV

#### WEIGHTS

Materials for weights

17.-(1) A person shall not make weights from any metal other than lead, except where the lead is inserted for the purpose of adjustment.

- (2) A person shall not make weights:
  - (a) from soft metals and soft alloys such as tin or solder; or
  - (b) composed of two or more different un alloyed metals.

Denomination of weights

18.-(1) A person shall -

- (a) put the name of the maker on a weight, in letters not exceeding half the size of the letters indicating the denomination.
- (2) Weights other than apothecaries' weights shall not be marked with more than one denomination.

*Weights and Measures (General) Regulations*

---

G.N. No. 229 (contd.)

Flaws

19. All weights shall:
- (a) be free from flaws and cavities; and
  - (b) be quite smooth on all surfaces.

Mode of  
adjusting  
weights

20. Weights of twenty grams or more shall:
- (a) have one adjusting hole on the under surface of the weight and shall not extend to the upper surface; and
  - (b) the hole shall be undercut and plugged with a lead of sufficient thickness which will cover the bottom of the hole to ensure that it remains securely in position.
- (2) The weights from-
- (a) 1 g to 10 g shall be solid, without an adjusting hole;
  - (a) 20 g to 50 g may have an adjusting hole; and
  - (b) 100 g and above shall have an adjusting hole.
- (3) The volume of the adjusting hole shall not be greater than  $\frac{1}{4}$  of the total volume of the weight and after the initial adjustment, approximately  $\frac{1}{2}$  of the total volume of the adjusting hole shall be empty.

Shape of  
weights

21.-(1) Weight shall have a simple geometric shape with no sharp edges, or cavities on their surface.

(2) The weights of a given weight set shall have the same shape in sub regulation (1), except for weights of one gram or less.

(3) The weights less than 1 g shall be flat polygonal sheets or wires, with shapes set out in the Second Schedule to these Regulations.

(4) Weights of nominal values from 1 g to 50 kg shall have the shapes as set out in the Second Schedule to these Regulations.

(5) Without prejudice to sub regulation (4), weights of 5 Kgs to 50 Kgs may have:

- (a) different shapes suitable to their method of handling;
  - (b) rigid handling devices embodied with weights such as axles, handles, hooks or eyes instead of a lifting knob; and
  - (c) rectangular parallelepipeds with rounded edges and a rigid handle.
- (6) Weights greater than or equal to 50kg may have cylindrical, rectangular or other suitable shapes and may be

G.N. No. 229 (contd.)

provided with rigid handling devices.

Permissible errors

22. The permissible errors on the verification of weights shall be as specified in Table I as set out in the Fourth Schedule to these Regulations.

Mode of stamping or certifying weights

23.-(1) Weights with an adjusting hole shall be stamped on the lead in the adjusting hole.

(2) Weights without an adjusting hole shall be certified in a manner to be prescribed by the Commissioner.

## PART V

### MEASURES OF LENGTH

Measures of length

24.-(1) Measures of length shall be-

- (a) made of steel, brass, , hard wood, woven tape or other material that may be approved by the Commissioner;
- (b) straight and strong;
- (c) clearly denominated, graduated and indelibly marked.

(2) Wooden measures of fifty centimeters or more in length shall have both ends capped with metal and the caps shall be riveted.

(3) Any measures with sliding or caliper arms shall have a play necessary for easy movement.

(4) A subdivided measure of length shall have its numbered divisions and subdivisions of longer lines than the minor graduations.

Denomination

25.-(1) The graduation mark for rigid measures of length shall be at-

- (a) every millimeter;
- (b) every millimeter for the first ten centimeters and thereafter at every five millimeters; and
- (c) every ten millimeters numbered.

(2) The graduation mark of flexible measures of length shall be clear, uniform, indelible and made to ensure easy and an unambiguous reading.

(3) The graduation lines shall be-

- (a) reasonably straight, perpendicular to the axis of the

G.N. No. 229 (contd.)

- tape measure and of uniform thickness throughout the length;
- (b) made to form a clear and distinct scale and their thickness does not cause any inaccuracy of reading.

Tension for linked and tape measures

26.-(1) Linked riband and tape measures shall be tested when subjected to a tension or pull as follows-

- (a) ordinary riband or tape measures....1 kg;
  - (b) metal riband or tape measures.....5 kg; and
  - (c) linked measures.....7 kg.
- (2) The measure under test shall be supported throughout its whole length on a plane and even surface.

Permissible errors

27. The permissible errors on the verification of measures of length shall be as set out in Table II of the Third Schedule to these Regulations.

Position of stamping

28. A person shall stamp:
- (a) measures of length at the beginning of the scale on each graduated side; and
  - (b) linked measures on a metal label or disc permanently attached to the measure, or on the brass handle.

## PART VI

### MEASURES OF CAPACITY

Material and construction

29.-(1) Measures of capacity shall be made of:

- (a) glass;
- (b) earthenware;
- (c) tin;
- (d) tin alloys;
- (e) pewter;
- (f) brass;
- (g) bronze;
- (h) copper;
- (i) tinplate;
- (j) white metal;
- (k) aluminium;

*G.N. No. 229 (contd.)*

- (l) nickel;
- (m) nickelled or nickel-plated steel or sheet iron;
- (n) enameled metal; or
- (o) any other material to be approved by the Commissioner.
- (2) The inner parts of measures made of brass, bronze or copper shall be tinned.
- (3) The coating of nickel on measures shall:
  - (a) be uniform; and
  - (b) nor show any sign of peeling.
- (4) Where there are strengthening ribs or bands inside the measure, such ribs or bands shall not show sub divisions by indentation or otherwise which may be mistaken with graduations.

Lips or retaining edges

30.-(1) The capacity defining line in measures fitted with a lip or retaining edge shall be sharp and regular.

(2) The lip or retaining edge of a measure shall not exceed the capacity of that measure by more than ten percent of the marked capacity.

False bottom

31. A measure which is not completely emptied when tilted to an angle of one hundred and twenty degrees from the vertical shall not be stamped.

Publican's measure

32.-(1) A publican's metal, glass or earthenware measure shall have a spout or projecting mouth and may have a bottom rim.

(2) Rim in measures of not more than five hundred millilitres shall not project more than ten millimeters below the bottom of the measure.

Dipping measures

33. Where a person uses a metal dipping measure of a capacity not exceeding two litres for the sale of milk:

- (a) the metal dipping measure shall be of circular or elliptical section with vertical sides; and
- (b) the height of metal dipping measure shall not differ by more than ten percent from one-and-a-half times the mean diameter of the section.



*Weights and Measures (General) Regulations*

---

G.N. No. 229 (contd.)

(2) The denomination on a glass measure in which the capacity is defined by a line shall be marked at the line.

(3) The denomination on an enameled metal measure shall be marked in a distinctly different colour from that of the body of the measure.

(4) The denominations on all subdivided measures shall be marked on the graduated strips or on the tablets as well as on the outside.

Apothecaries  
measures

40. Apothecaries measures may be of cylindrical or conical form.

(2) The width of the smallest graduation on a glass measure shall not be less than two millimeters.

(3) A measure marked with equivalents in weight may be permitted provided that the words "of water" are marked on the outside in addition to the denomination.

Method of  
testing

41.-(1) Every measure shall be tested by filling the standard with water and emptying the contents into the measure submitted for verification.

(2) Where the capacity is indicated by a line, the measure shall be tested to the bottom of the line.

(3) A measure provided with a lip or retaining edge shall be tested to the bottom of the lip or retaining edge.

Meniscus

42. When testing a glass measure of the capacity which is not defined by the brim, the level of water shall be taken at the bottom of the meniscus.

Permissible  
errors

43. The permissible errors on the verification of measures of capacity and apothecaries measures shall be as specified in Table III, set out in the Fourth Schedule to these Regulations.

Method of  
stamping

44.-(1) The stamp of verification shall, in the case of glass, earthenware and enameled metal measures, be etched or sand blasted beneath or near the denomination.

(2) The stamp of verification shall-

(a) in metal measures other than lip or rimmed measures be stamped near the denomination;

(b) in metal measures provided with a lip or retaining edge be stamped on the bottom of the inside of the lip or retaining edge;

*G.N. No. 229 (contd.)*

- (c) in graduated metal measures be stamped on a solder stud affixed to the inside strip or tablet near to the top graduation and on the outside of the measure near the denomination;
- (d) on sheet metal measures be stamped on solder stud affixed to it.

PART VII

WEIGHING INSTRUMENTS

Conditions for structure of weighing instruments

45. The weighing instrument shall not have-
- (a) a broken scoop, pan or plate; or
  - (b) a plate which is chipped, cracked or porous to such an extent that it has become readily absorbent; or
  - (c) a counterpoise weights representing a greater or less weight than the marked capacity of the instrument.

Marking of weighing capacity

- 46.-(1) The weighing capacity of a weighing instrument shall be prominently and indelibly marked on an instrument.
- (2) The full capacity in dial machines fitted with a supplementary weigh bar shall be marked on a prominent part of the machine.

Materials of construction

- 47.-(1) Beams, steelyards, levers, rods, links, legs and stays shall be constructed of metal.
- (2) Knife edges and a bearing shall be made of hard steel, agate or other material approved by the Commissioner and be fitted so as to allow the beam or steelyard to move easily.
- (3) The whole length of a knife edge shall rest on the bearing and be fitted such that it does not twist or otherwise get out of alignment.

Graduations

- 48.-(1) The graduations on a steelyard shall consist of defined notches or sharply incised lines which clearly indicate the position of all sliding poises.
- (2) The indications on the dials of platform machines or weighbridges shall be indelibly marked by fine lines.

Plug for

- 49.-(1) A lead plug for receiving the stamp of



*Weights and Measures (General) Regulations*

---

*G.N. No. 229 (contd.)*

verification stamp	<p>verification in every weighing instrument shall be inserted in an easily accessible part of the instrument.</p> <p>(2) The hole in which the stamp in sub regulation (1) is inserted shall be undercut with the face of the plug flush with the metal part.</p>
Loose counterpoise and travelling poise	<p>50. A person shall not use a weighing instrument unless:</p> <p>(a) such counterpoise weights have one undercut adjusting hole containing sufficient lead to cover the bottom of the hole;</p> <p>(b) a travelling poise with loose material shall not be permitted.</p>
Special trades	<p>51.A weighing instrument used for weighing the following articles shall be of accuracy Class II or I—</p> <p>(a) precious metals;</p> <p>(b) precious stones;</p> <p>(c) chemicals;</p> <p>(d) drugs.</p>
Position when testing	<p>52. A person shall:</p> <p>(a) test movable instruments provided with a base, on a level plane;</p> <p>(b) suspend instruments which are suspended in use when testing; and</p> <p>(c) test a weighing instrument to its maximum capacity.</p>
Test at maximum load and tests for sensitiveness	<p>53. A weighing instrument of the vibrating type shall be tested for sensitiveness by loading it with its maximum load with the beam or steelyard in a horizontal position and ascertaining that it turns with the addition of the amount shown in Table IV, V, VI, VII, VIII, IX and X as set out in the Fourth Schedule to these Regulations.</p>
Tests for error	<p>54. A weighing instrument of the vibrating type shall be tested for error by ascertaining the weight in excess or deficiency required to bring the beam or steelyard of the instrument to a horizontal position when fully loaded.</p>

*G.N. No. 229 (contd.)*

Balanced  
Instrument

55. An assizer shall ascertain that-

- (a) an instrument is properly balanced when not loaded;
- (b) he has sufficient room for oscillation; and
- (c) the beam or steelyard returns to the position of equilibrium or that the indicator returns to the zero mark when a load is removed.

Weighing  
range

56. A weighing range or segment shall be defined by its interval size, its minimum capacity, and its maximum capacity.

PART VIII  
ELECTRONIC MEASURING INSTRUMENTS

Registration

57.-(1) Registration by electronic instrument shall-

- (a) include visual indication and recorded representation of quantity, and may include unit price and monetary value;
- (b) be clear, definite and easily legible under conditions of normal use of an electronic instrument.

(2) An electronic instrument shall be provided with appropriate means of registration that for the class, type or design and for its intended service, installation and use.

(3) Where an electronic instrument is installed with two or more means of registration that have the same units of measurement, the registration shall, where the values of minimum increment of registration are the same, be exactly equal.

Special  
requirements

58. Where an electronic instrument requires special requirements on electrical power supply, the frequency, voltage, current and any special limitations on the stability or quality of power supply required to enable the instrument to measure accurately, shall be marked on the instrument.

Zero tracking  
mechanism

59.-(1) The overall range of the zero-tracking mechanism of an electronic instrument shall not exceed four per cent of the rated capacity of an instrument.

(2) An electronic instrument may be equipped with zeroing devices whose operation shall result in accurate zeroing and which do not give incorrect measuring results.

*Weights and Measures (General) Regulations*

---

*G.N. No. 229 (contd.)*

- Leveling 60. An electronic instrument shall be fitted with a levelling device and a level indicator.
- Tare devices 61.-(1) An electronic instrument shall have one or more tare devices.  
(2) The operation of the tare devices shall result in accurate zeroing and ensure correct net weighing.  
(3) The operation of the preset tare device shall ensure correct determination of the calculated net value.
- Contrast 62. The luminosity contrast between the visual indications and the background of the indicator of an electronic instrument shall have a ratio equal to or greater than four to one
- Record of registration 63. Where an electronic instrument provides a printed record of the registration on a ticket or form, the ticket or form shall contain a statement of-  
(a) the quantity measured in the transaction;  
(b) the unit price for the commodity measured when the computed price is shown;  
(c) the name, symbol or abbreviation appropriate to the unit of registered measurement applicable to the unit price and total price; and  
(d) any other information as may be required by these Regulations.
- Starting position 64. An electronic instrument equipped with an indicator or printer shall be capable of giving a visual or printed indication that the device has been properly returned to its starting position before any commodity is measured.
- Means of indication 65. Electronic digital means of indication for an electronic instrument shall-  
(a) have digits of the same height;  
(b) set apart a decimal sub multiple of the unit by a decimal point;  
(c) have bright displayed digits and other information that are easily redouble under normal conditions of use.
- Marking 66.-(1) There shall be a mark, in association with digital means of indication, on an electronic instrument defining words,

*Weights and Measures (General) Regulations*

---

*G.N. No. 229 (contd.)*

name, symbol or abbreviation for the unit or units of measurement appropriate in size.

(2) Any mark in association with digital registration shall not be obliterated or illegible under normal conditions of use.

Indicator

67. An indicator and printer for monetary value shall conform to the same specifications as the indicator and printer for registration of units of quantity.

Repeatability

68. An electronic instrument shall be capable of repeating its registration for each identical load or quantity delivered regardless of repeated manipulations of any or all of the elements of the electronic instrument in a manner approximating normal conditions of its use.

Installation and use

69.-(1) A person shall not install and use an electronic instrument in the manner that it is protected from abnormal environmental factors that could have an adverse effect on its performance.

(2) A person shall install electronic instrument, other than a scale used for prepackaging in a manner that the indications of the primary means of indication can be read by any party to the transaction for which it is being used:

Provided that, if such an installation is not practicable, a secondary means of indication may be provided to allow the party to the indications.

Location of primary indicator

70. A primary indicator of an electronic instrument shall be located as to allow an unobstructed view of the load-receiving element or the delivery outlet of an electronic instrument.

Multi-interval instrument

71.-(1) A multi-interval instrument shall be tested as a single instrument.

(2) Increasing and decreasing load tests for a multi-interval instrument shall be conducted the same as a single interval or single range instrument.

Permissible errors

72.-(1) An error of indication shall not exceed the maximum permissible error of indication as shown in table IV as set out in the Fourth Schedule to these Regulations.

*G.N. No. 229 (contd.)*

(2) The maximum permissible errors set out in sub regulation (1) shall apply to the net value and tare value for all possible loads, excluding preset tare values.

(3) The limits of error, in a multiple range scale, shall be determined on the basis of the class of the device and the value of the verification scale interval “e” of the partial range corresponding to the load applied.

Manner of sealing

73. An electronic measuring instrument shall be provided with a suitable sealing arrangement to receive the stamp of verification or sticker.

## PART IX

### BEAM SCALES

Classification

74. Beam scales shall be divided into three classes-

- (a) Class A which includes only chemical and assay balances and other beam scales provided by means for relieving all the bearings and knife edges which meet the requirements of Table V as set out in the Fourth Schedule to these Regulations and need not marked with a class mark;
- (b) Class B which includes only beam scales which meet the requirements of Table VI as set out in the Fourth Schedule to these Regulations;
- (c) Class C which includes all beam scales which meet the requirements of Table VII as set out in the Third Schedule to these Regulations.

Every beam scale falling within either Class B or C shall be indelibly marked with the appropriate class mark.

Prohibition of certain types

75. The following shall not be admitted for verification-

- (a) accelerating beam scales;
- (b) new swan neck beam scales of a capacity of less than 15 kg or the beam of which is less than sixty centimeters in length between the terminal knife edges;
- (c) swan neck beam scales not fitted with flat end bearing and swivel hooks;
- (d) beam scales with loaded weight pans;

*G.N. No. 229 (contd.)*

- (e) beam scales of a capacity of less than 100 kg with wooden scale boards.

Balancing mechanism

76.-(1) An attachment for adjusting the balance of a beam scale shall be permanently fastened.

(2) A ball or a box fitted for occasional adjustment shall be fixed in a manner that it cannot easily be tampered with.

(3) A beam scale with wooden scale boards shall be provided with a balance ball or box.

Half-load test

77. A beam scale with the pans loaded to half capacity shall not be verified if it loses accuracy when knife edges or bearings are laterally moved forwards or backwards within their limits of movement.

Position of loading

78. A beam scale shall not be verified if it is not just, irrespective of the position of the load on the pan.

Permissible errors

79. The permissible errors on the verification of beam scales shall be as specified in Tables IV, V and VI, as set out in the Fourth Schedule to these Regulations.

Position of stamping

80.-(1) The stamping plug on beam scale shall be inserted immediately above or below the central knife edge.

(2) Class A beam scale may be stamped on the pans in case where the delicate construction of the beam might be affected by the insertion of a plug.

## PART X

### COUNTER MACHINES

Construction of counter machines

81.-(1) Where the beam of a body has two sides, it shall be connected by not less than two cross bars;

(2) The supports of the pans shall be of suitable rigid structure, such as cross members strengthened by straps.

(3) A centre fork shall be fixed so that it cannot twist or get out of place.

(4) The bearing surface, knife edges and points of contact of all stays, loops and hooks shall have hardness of at least 58 Rockwell C scale.

*Weights and Measures (General) Regulations*

---

G.N. No. 229 (contd.)

(5) A counter machine shall have a balance box or other receptacle for balancing material fixed beneath one of the pans to contain loose material not exceeding one percent of the capacity of the machine.

Prohibition of certain types

82. The following shall not be admitted for verification

- (a) accelerating counter machines;
- (b) counter machines of the "Roberval" type in which the stays forming the lower side of the parallelogram are not in one piece.

Fall on counter machines

83. The minimum "fall" either way on counter machines shall be as follows-

capacity	millimeter
not exceeding 2kg.	6
above 2kg. and not exceeding 5kg	8
above 5kg and not exceeding 10kg.	10
above 10kg and not exceeding 25kg.	12
above 25kg and not exceeding 50kg.	13

Lateral movement test

84. A instrument with the pans loaded to half capacity shall not be verified if it loses accuracy when knife edges or bearings are laterally moved forwards or backwards within their limits of movement.

Position of weights during test

85. Where the goods pan is not in the form of a scoop, the counter machine shall indicate the same weight within half the prescribed limits of error, if the centre of a load equal to half the capacity placed on the goods pan is moved anywhere within a distance from the centre equal to one-third of the length of the pan or if the pan has a vertical side, against the middle of that side the weight being entirely on the weights pan, but in any position on it.

Method of testing

86. The counter machine shall be tested for-

- (a) sensitivity at full capacity; and
- (b) error at half load and full load

Counter machines with

87. When the goods pan is in the form of a scoop, the

*G.N. No. 229 (contd.)*

scoops prescribed limits of error shall not be exceeded, if half the full load is placed against the middle of the back of the scoop and the other half in any position on the scoop.

Permissible errors 88. The errors permissible on the verification of counter machines shall be as specified in Table VIII as set out in the Fourth Schedule of these Regulations.

Stamping 89. The stamping plug on counter machine shall be inserted in an easily accessible part of the beam or body of the machine.

## PART XI

### SPRING BALANCES

Suspension 90. A spring balance of a capacity of not more than 15kg with the goods pan below the spring shall be permanently suspended from a stand, support or bracket.

Width of index finger 91. The width of an extremity of the index finger shall not exceed 0.8mm and not more than 2.5mm from the scale or dial.

Dimensions of graduations 92.-(1) The scale shall be graduated into equal parts and the minimum.  
(2) The graduation of the scale shall not be-  
(a) less than 1.6mm for a capacity of not exceeding 15kg; and  
(b) less than 3.2mm for a capacity of 20kg and above.

Range of adjustable indicator 93. The range of an adjustable indicator shall not exceed one percent of the capacity of the instrument.

Interval between graduations 94.-(1) The weights corresponding to the interval between consecutive graduation marks shall be as follows-

Capacity	Limit
500 g	not exceeding 3 g
1 kg to 3 kg	not exceeding 7 g
5 kg to 7 kg	not exceeding 14 g
10 kg to 15 kg	not exceeding 28 g



*Weights and Measures (General) Regulations*

---

G.N. No. 229 (contd.)

20 kg to 30 kg	not exceeding	55 g
50 kg and over	not exceeding	1/200th of capacity

States the obvious, what has been stated in sub regulation (1)

(2) Where a graduation commences at a fixed load and there is no load, the position of the indicator shall be indicated by a zero mark.

Position of the weight during testing

95.-(1) When the pan is above the spring and not in the form of a scoop, the spring balance shall indicate the same weight within half the prescribed limits of error, if the centre of a load equal to half the capacity placed on the goods pan is moved anywhere within a distance from the centre equal to one-third of the length of the pan or if the pan has a vertical side, against the middle of that side the weight being entirely on the pan, but in any position on it.

(2) When the goods pan is in the form of a scoop the prescribed limits of error shall not be exceeded if half the full load is placed against the middle of the back of the scoop and the other half in any position on the scoop.

Testing of graduations

96. Each-

- (a) numbered graduation, shall be tested; and
- (b) intermediate graduation, may be tested.

(2) An instrument shall be deemed to be just if it satisfies a forward and backward test.

Fatigue test

97.-(1) A spring balance may be tested for efficiency or ability to recover by loading with a load equal to its maximum capacity for a period not exceeding twenty four hours and be tested for accuracy after four hours.

Permissible errors

98.-(1) A person who uses a spring balance of a capacity of not more than 15 kg shall:

- (a) satisfy the requirements as regards error of counter machine of similar capacity; and
- (b) in case of a spring balance of a capacity of 20 kg and above, ensure that the error does not exceed the weight

G.N. No. 229 (contd.)

corresponding to a quarter of the interval between consecutive graduations.

Testing for sensitivity

99. A person shall not test a spring balance for sensitivity.

Position of stamping

100. The stamping plug on a spring balance shall pass through the dial and the frame.

## PART XII

### DEAD-WEIGHT MACHINES

Construction

101.-(1) The bearing surfaces and points of contact of hooks, stays and loops shall have hardness of at least 58 Rockwell C scale.

(2) The center shall have rectangular shoulder fitted and firmly secured into rectangular holes.

(3) The bearing surface of the adjustable slides shall be made of hard steel and the stems holding them in position be secured by lock nuts.

(4) The goods platform shall not exceed the length and width of the beam.

(5) Folding wings shall not increase the dimensions exceeding one-third in either direction.

(6) Platforms shall be made of metal or hard wood.

(7) The minimum fall in dead-weight machines shall be 16mm both ways for vibrating machines and 22mm one way for accelerating machines.

Balancing

102.-(1) Loose balancing material shall be contained in a balance box permanently fixed beneath one platform and its weight not exceeding one percent of the capacity of the machine.

(2) Balancing materials, other than loose materials, shall be in one piece and securely attached to the machine.

(3) Load of one-quarter the capacity is placed successively at the middle of the front and back of each platform and centrally over the knife edges on each side, the allowance for error shall not be exceeded half the allowed error.

Permissible

103.-(1) Permissible errors in the verification of dead-

*G.N. No. 229 (contd.)*

errors weight machines shall be the same as for platform machines of similar capacity.

(2) The load shall, in carrying out the tests for sensitiveness and error, be distributed over the platforms.

Position of stamping plug 104. The stamping plug on dead-weight machines shall be inserted in a conspicuous and easily accessible part of the beam of the machine

### PART XIII

#### PLATFORM MACHINES AND WEIGHBRIDGES

Test in situ 105. Weighbridges and dormant platform machines shall be verified and stamped in situ in addition to any preliminary test on the manufacturer's premises.

Foundations 106. A person shall verify and stamp weighbridges and dormant platform machines shall be permitted if the foundation or supporting base is sufficiently firm to be capable of carrying the maximum load without change of form or level.

Construction 107.-(1) The steelyard of a machine shall -  
(a) be in a straight plane on its upper surface or edge; and  
(b) not involve easily removable parts except the support for the counterpoises.  
(2) A stop shall be affixed on the steelyard to prevent the sliding poise or poises from travelling behind the zero graduation.  
(3) The steelyard or registering mechanism may be confined in a locked box or case, provided that the indications or graduations are visible.

Travel 108.-(1) The minimum travel of the steelyard in platform machines shall be 10 millimeter both ways for vibrating machines, and 16 millimeter one way for accelerating machines.  
(2) The minimum travel of the steelyard in weighbridges shall be 13 millimeters both ways for vibrating machines, and 19 millimeter one way for accelerating machines.

Counterpoises 109.-(1) Where a counterpoise is used in connection with

G.N. No. 229 (contd.)

a loose receptacle or frame it shall be of a shape distinct from all the other counterpoises.

(2) All loose counterpoises shall be identified with the machine by a number or other indelible mark and be marked with their equivalent weight in the following manner,  
= 50 kg.

Balancing

110.-(1) A weighbridge and platform machine shall be fitted with balancing mechanisms capable of being operated by means of a detachable key.

(2) The range of balance of the weigh bridge and platform machine shall not exceed-

- (a) one-half percent of the capacity of the platform machine, and not less than one-eighth percent each way.
- (b) one percent of the capacity of the weighbridge and not less than one-fourth percent each way.

Gravity balls

111. Where a gravity ball is provided, it shall, unless the ball is completely enclosed, be adjustable by means of a mechanical appliance.

Self-indicating machines

112. The following provisions shall apply to weighbridges and platform machines fitted with dials-

- (a) racks and pinions shall be made of material of high anti-friction factor;
- (b) the registration mechanism and cylinders or tanks containing liquid (if any) shall be protected from dust and excessive variations of temperature;
- (c) the graduation marks shall be clear and distinct and shall not-
  - (i) exceed 8 millimeter in width on platform machines;
  - (ii) exceed 16 millimeter in width on weighbridges;
  - (iii) be less than 32 millimeter apart, measured from centre to centre; and denominated subdivisions shall be of longer lines than minor graduations;
- (d) the extremity of the indicator shall in no position

*Weights and Measures (General) Regulations*

---

G.N. No. 229 (contd.)

be at the greater distance from the graduated surface of the dial than 45 millimeter; and shall be made to meet, but not obscure, the graduation marks.

Mode of testing

113.-(1) Each-

- (a) numbered graduation, shall be tested; and
  - (b) minor graduations, may be tested
- (2) Each loose counterpoise shall be tested
- (3) A platform machine and weighbridge shall be tested to its maximum capacity.
- (4) Where a sufficient standard weight is not available to test a machine to its full capacity, it may, be loaded with suitable heavy material within one third of its maximum capacity.

Test at quarter load

114. A person shall not exceed half the allowance for error at maximum capacity where a load equal to one-quarter the maximum capacity is placed successively at the middle, near the ends and at the corners of a platform.

Relieving gear

115. Where a platform machine or weighbridge is fitted with a relieving gear the prescribed limits of error shall not be exceeded the limit when the machine is put steadily out of and into gear.

(2) The plate or platform shall be entirely disengaged from its bearings when the machine is in relief.

Permissible errors

116. The permissible errors on the verification of weighbridges and platform machines shall be as specified in Table IX as set out in the Fourth Schedule to these Regulations.

Position of stamping plug

117. The stamping plug on:

- (a) weighbridges and platform machines, other than self-indicators shall be inserted in the shoulder or the nose-end of the steelyard; and
- (b) self-indicating machines shall be inserted in the dial or in the shoulder.

(2) Loose counterpoises shall, after the completion of the test, be date-marked upon the lead in the adjusting hole.

PART XIV

CRANE MACHINES

- Construction                    118. A Manufacturer of a crane machine shall:  
(a) comply with the constructional requirements of a platform machine; and  
(b) shall ensure that the working parts of a crane machine are enclosed and protected from damp and dust.
- Balancing                        119. The balancing range or adjusting mechanism, where provided, shall not exceed two percent of the capacity of the machine.
- Mode of testing                120. An assizer shall test a crane machine and a numbered graduation of a crane machine forwards and backwards to establish its full working capacity.
- Permissible errors            121. The permissible errors on the verification of a crane machine shall be -  
(a) below capacity of 1000 kilogram the same as for platform machines of the same capacity; and  
(b) not less than 1000 kilogram the same as for weighbridges of the same capacity.
- Position of stamping plug    122.-(1) The stamping plug on a crane machine shall be inserted in a conspicuous part of the steelyard or dial of the machine.  
(2) A sealing mechanism for an electronic crane machine shall be in such a manner that no intervention can be performed without breaking the seal.

PART XV

AUTOMATIC MACHINES

- Adjusting mechanism        123. A manufacture of automatic machines shall ensure that the adjusting mechanism is secured in such a way that it cannot be tampered with.
- Mode of                            124. An assizer and manufacture shall ensure that

*G.N. No. 229 (contd.)*

testing machines are tested by the application of standard weights or measures.

Totalizing machines 125. Where an automatic machine has a totalizer, it shall be tested by passing the machine over ten minimum loads, ten maximum loads, and ten loads of the mean between the minimum and maximum.

Permissible errors 126. The permissible errors on the verification of automatic machine shall be as specified in Table X as set out in the Fourth Schedule to these Regulations.

Certification 127. An Assizer shall, after certifying an automatic machine-  
(a) affix a verification sticker on a conspicuous part of a machine; and  
(b) issue a certificate of verification.

## PART XVI

### SELF-INDICATING WEIGHING INSTRUMENTS

Graduations 128. A person shall, when testing a for self-indicating weighing instrument, ensure that:  
(a) the graduation marks are clear and distinct;  
(b) the denominated subdivisions have longer lines than minor graduations;  
(c) the graduations on instruments for counter use and suspended weighers do not exceed 0.4 Millimeter in width; and  
(d) the minimum distance between minor graduations measured from the centre to centre are not less than 1.6 Millimeters.

Pointer 129. The extremity of a pointer shall not exceed:  
(a) 0.4 millimeter in width; and  
(b) 4.5 millimeter from the chart.

Value of graduation 130. The maximum value of the smallest subdivision on the chart in self-indicating instruments of a capacity not exceeding 75 kilograms shall not exceed the amount set out in the following table-

*Weights and Measures (General) Regulations*

---

*G.N. No. 229 (contd.)*

	Capacity of Instrument	Maximum Value of smallest division
	Under 1 kg	10g
	1 kg and under 10 kg	15g
	10 kg and not exceeding 15 kg.	30g
	Over 15 kg and not exceeding 30kg	60g
	Over 30 kg	110g
Mode of testing	131. A person:  (a) shall test all numbered graduations forwards and backwards; and  (b) may test intermediate graduations.	
Permissible errors	132. The permissible errors on verification of self-indicating instruments shall be as set out in Table XI of in the Fourth Schedule to these regulations.	
Position of stamping	133. An assizer shall ensure that the stamping plug on a self-indicating instrument is placed on a conspicuous and essential part of the instrument, in addition to any seals which may be prescribed by the Commissioner.	

PART XVII

VEHICLE TANKS

Construction and design	134. A manufacture shall construct a vehicle tank in accordance with these Regulations and in particular, the vehicle tank shall:  (a) be of such shape, material, reinforcing elements and shape such that the tank is sufficiently unaffected by atmospheric agents and not subject to distortion under any rated operating conditions;  (b) comply with other regulations concerning transport of dangerous liquids, safety at work, the construction of pressure vessels and protection of pressure vessels, protection against fire, quality of liquid transported and health;  (c) be pressure tested;	
-------------------------	--	--



G.N. No. 229 (contd.)

- (d) be leak tested by using water at atmospheric pressure;
- (e) be fitted with an approved device through or by means of which the liquid can be measured or calibrated in the manner prescribed by the Regulations;
- (f) after being filled, show no traces of leakage or dampness at the joints;
- (g) be of the reference height H which does not vary during filling by more than the following two values-  
2 mm;  
H/1000; and
- (h) be of the capacity of the compartment which does not change by more than 1/1000 of its measured volume when the neighboring compartments are filled or emptied.

Construction of quantity indicators, piping, gauges and valves

135. A manufacturer shall ensure that a quantity indicator, gauge, piping and valve is such strength, design, construction and material that they may reasonably withstand ordinary usage without the accuracy of the tank being impaired.

Complete delivery required

136. A manufacture shall ensure that-
- (a) a delivery piping connected to a tank is designed such that, when the vehicle on which it is mounted is standing on a level plane, complete delivery can be made from the tank or any of its compartments;
  - (b) the lower general matrix of a tank shall has a slope of at least two degrees with the vehicle on level ground as to ensure complete drainage;
  - (c) where a tank is fitted with an approved meter, the delivery piping and manifold outlet is designed to preclude the liquid from being trapped in any empty compartment while delivering from a compartment which is full;
  - (d) the connection between the stop valve of the tank and pipe, other than the tank designed for a special purpose, by shortest and easily assembled detachable couplings;
  - (e) fitted manhole is on the upper part of the tank and welded; and

G.N. No. 229 (contd.)

- (f) where the side walls of the manhole penetrate the tank shell, the formation of air pockets on the upper part of the shell is avoided by providing orifices or cutouts at the level of the upper internal general matrix.

Ventilation and filler openings

**137.** A manufacture shall ensure that a compartment or tank-

- (a) well ventilated to prevent the formation of air pockets on filling or retention of liquid on emptying in all positions of use;
- (b) has a filler opening constructed in a manner and size which permits visual internal inspection;
- (c) has an anti-wave device with orifices and reinforcing elements of a shape and does not hinder the filling, draining and checking the emptiness of the tank;
- (d) does not have a place of deadwood for adjusting the capacity to a given value or any other body which, when changed or removed, could modify the capacity of the tank.

(2) A compartment or tank which is constructed to deliver a fixed quantity of liquid shall be numbered and indelibly marked in the following manner-

Capacity	*	Litres
* means numerical value of the capacity		

(3) Where a tank has more than one compartment, each compartment together with its outlet and valve shall be numbered.

Position of indicator

**138.** A manufacturer shall ensure that indicator or other approved device is:

- (a) provided for each compartment;
- (b) centrally situated in respect to-
  - (i) the longitudinal and diametrical axes in cylindrical tanks; and
  - (ii) the longitudinal and major axes in elliptical tanks.

Design and

**139.** A manufacturer shall ensure that:

*G.N. No. 229 (contd.)*

sealing of indicators

- (a) the quantity-indicator in a tank or compartment is constructed as to deliver a fixed quantity function within a manhole centrally situated on the top of a tank or compartment; and
- (b) the quantity indicator in a tank or compartment is fixed rigidly to indicate the centre of the manhole.
- (c) by means of a plated or polished flat circular metal disc of at least 2.5 mm diameter, defines the height to which the tank or compartment is to be filled in order to contain its marked capacity; and
- (d) an adjustable indicator is constructed in a manner that can be sealed to prevent any change in its position without breaking the seal.

Gauges to be identified with compartments

140. Graduated gauges or other approved devices for the measurement of liquid in a tank or compartment shall be identified-

- (a) with the tank or compartment to which they belong;
- (b) by means of a number indelibly marked to them; and
- (c) by means of a number corresponding to a number similarly marked on the tank or compartment.

Provision for expansion

141. A manufacturer shall ensure that an indicator and gauge in a tank or compartment shall be placed or graduated in a manner, in which when the tank or compartment is filled with the declared maximum quantity is designed to contain, and retain not less than 2.5 percent of the capacity of the tank or compartment.

Method of testing

142.-(1) An assizer shall ensure that:

- (a) all tests for checking the accuracy of tanks compartments shall be made by means of meter or against official standard measures of capacity, with the tank or compartment in a level position and stop valve closed;
- (b) where a standard measure which requires a fixed position is used, it shall be placed in a manner that the test medium has a free run into the tank compartment and there is no leakage at the hose leading from the measure; and

*G.N. No. 229 (contd.)*

- (c) the shape of the tank shall be such that in a zone where the level of the contained liquid is gauged, a sensitivity of at least 2mm for 1/1000 of contained volume is attained.

(2) An assizer shall, after testing a vehicle tank, a certificate of verification as set out in Form F of the First schedule to these Regulations together with a sticker and calibration chart.

Charts of gauges

143. Where graduated gauge is used for indicating the liquid contents of compartment, an assizer shall:

- (a) make and retain for future reference an accurate chart of the quantity marks on each such gauge; and
- (b) number the chart to reflect the number marked on the gauge.

Emergency valves

144. Where an emergency valve is provided for closing the discharge outlets from a tank or compartment, the verification shall be made while the emergency valve is open.

Permissible error

145. The permitted error in excess or deficiency on a tank or compartment shall be as follows-

- (a) error on verification  $\pm$  0.2 percent of the nominal volume;
- (b) error on re-verification  $\pm$  0.5 percent of measured volume.

Construction licensing

146.-(1) A person who intends to carry on the business of constructing rail, vehicle tanks or any other assembly used for measurements and delivery of fluids shall apply to the Commissioner for a licence.

(2) An application for a license under this regulations shall be in writing specifying-

- (a) the name of the applicant;
- (b) his proposed principal place of business and address;
- (c) the qualification or experience of the applicant; and
- (d) any other particulars which the Commissioner may deem necessary.

(3) Notwithstanding with any other law, the Commissioner shall, is satisfied that the applicant has-

- (a) sufficient technical competence and resources to carry out satisfactorily the construction of rail or

*G.N. No. 229 (contd.)*

- vehicle tanks;
- (b) at his disposal the tools and machinery to carry out the construction satisfactorily;
  - (c) sufficient knowledge to enable him to carry out the grant of a license in the format set out in Form E of the First Schedule to these Regulations
  - (4) The Commissioner shall grant a licence in the format set out in Form E of the First Schedule to these Regulations, upon payment of fees prescribed.
- Validity of licence                      147. A license shall be valid for a period of one year and be paid in respect of every license or renewal of license a fee as prescribed in these Regulations.
- Cancellation of the licence                      148.-(1) The Commissioner may at any time cancel any license if the licensee fails to comply with any obligations imposed on him by these Regulations.  
(2) The licence issued in subregulation (1) may be renewed upon payment of the prescribed fees.
- Appeal to the Minister                      149. A person aggrieved by the refusal of the Commissioner to grant a license or by the cancellation of a license may appeal to the Minister against the refusal or cancellation and the decision by the Minister shall be final and conclusive.
- Prohibition of construction of vehicles or tanks                      150. A person shall not, whether for a gain or otherwise, construct rail or vehicle tanks except under and in accordance with these Regulations.
- Penalty                      151. A person who contravenes the provisions of these Regulations commits an offence and is liable to a penalty specified in the Act.

## PART XVIII

### LIQUID MEASURING PUMPS

- Prohibition of certain types                      152. A liquid measuring pump for the sale of liquids of low viscosity in the presence of the purchaser shall not be permitted unless it is-

*G.N. No. 229 (contd.)*

- (a) provided with a measuring chamber or chambers constructed to permit a clear and unobstructed view by the purchaser of the contents of such measuring chamber or chambers;
- (b) constructed to deliver measured quantities at one outlet; and
- (c) provided with an individual sales indicator.

Measuring pump

153. It is the duty of:

- (a) the manufacturer to ensure that a liquid measuring pump of fixed type is:
  - (i) plumped; and
  - (ii) securely fixed on the level base and the longitudinal axis of the measuring chamber; and
- (b) an assizer to ensure that a liquid measuring pump of fixed type is:
  - (i) verified; and
  - (ii) sealed and affixed with a verification sticker

Denomination

154.-(1) A Manufacture shall clearly and indelibly mark the denomination of a measuring chamber shall be clearly and indelibly marked on the outside part of the body.

(2) Where the unit of measurement is boldly marked on the measuring chamber or the dial, an indication of quantity on the dial of individual sales indicator may be shown by figures.

Prohibition of certain markings

155. A manufacture shall not place a notice, statement or mark on liquid measuring pump which might be mistaken with a verification mark.

Sales indicators

156. A manufacture shall ensure that an individual sales indicator is:

- (a) capable of being readily re-set to zero; and
- (b) advanced by proper operation of the instrument.
- (c) an counting or totalizing device is arranged as to avoid confusion between them and an individual sales indicator.

Marking of graduations

157. A graduated scale of quantities shall be denominated in numerical sequence in one direction

*Weights and Measures (General) Regulations*

---

G.N. No. 229 (contd.)

Discharge  
signals

158. A person shall not use:

- (a) audible or any other signal of discharge which can be operated before the movement of the individual sales indicator shall not be permitted; or
- (b) a flexible discharge hose with a length exceeding four meters

Swing arms,  
flexible pipes  
and nozzles

159. A Manufacture shall ensure that a swing arm or other rigid form of extension pipe is constructed in a manner so as to:

- (a) empty itself completely through the delivery outlet;
- (b) remain permanently filled up to its connection to the discharge pipe or hose;
- (c) a flexible hose with an arm or pipe which empties itself on delivery, is arrange as to provide for complete drainage of the liquid; and
- (d) a nozzle capable of trapping any portion of the liquid being delivered, is not attach and to the discharged hose when opened.

Sight glasses

160. A measuring instrument may be provided with sight glasses, observation windows or other means approved by the Commissioner for showing clearly that any measuring chamber is properly charged and discharged.

Test under  
working  
conditions

161. An assizer shall test a liquid measuring pump and the liquid fuel or oil which the instrument is intended to deliver, under practical working conditions.

Testing a  
liquid  
measuring  
instrument

162. A person shall, before testing any liquid measuring-

- (a) pump for accuracy, test the instrument for leakage with the liquid which the instrument intends to deliver, over a reasonable period of time; or
- (b) instrument fitted with a flexible discharge hose, pass liquid through the instrument as to wet the hose.

*G.N. No. 229 (contd.)*

Permissible errors

163. An Assizer shall ensure that:

- (a) the permissible errors on the verification of liquid measuring pump shall be as specified in Table XII set out in the Fourth Schedule to these Regulations.
- (b) a speed of operation shall be uniform in a single delivery.
- (c) a specified error shall not be exceeded at optimal speed of operation.

Test by the owner or user

164. An owner or user of liquid measuring pump shall have in his possession a verified check measure whose capacity is not less than 20 litres used to ascertain the accuracy of his pumps every day before commencing business of the respective day.

Mode of Filling Measures of Capacity

165. A pump attendant shall use a measure of capacity of 20 litres having a portion made of metal or other suitable material:

- (a) being the stamp verification;
- (b) extending from the lower end;
- (c) having the upper portion made wholly or partially of glass or other transparent material so that the level of the surface of the contents may be clearly seen;
- (d) having the level line distinctly marked upon the transparent prior,

for measuring liquids.

(2) The pump attendants shall ensure that the container is filled to the level of the line so marked before commencing business on each day.

Provision of seals and sticker

166.-(1) An owner shall ensure that every stop or other adjustable part of a liquid measuring pump affecting or likely to affect the quantity delivered a protected in a manner as may be directed by the Commissioner.

(2) A stamp of verification shall be placed on each protective device.

(3) An assizer shall seal the dispensing pump and place a verification sticker on both sides of the readings of a fuel dispensing pump.



PART XIX

WEIGHTS, MEASURES AND INSTRUMENTS OF THE METRIC SYSTEM

- Permissible errors                    167. The permissible errors in metric weights and measures shall be as specified in Tables I, II, III and XIII as set out in the Fourth Schedule to these Regulations.
- Marking                                168. Weights and measures of capacity shall be marked in metric denominations as indicated in table XIII as set out in the Fourth Schedule to these Regulations.
- Weights                                169.-(1) Manufacturer Every iron metric weight and loose counterpoise shall be of hexagonal shape.  
  (2) Metric weights other than iron weights and loose counterpoises shall be cylindrical, hexagonal, flat or of wire.  
  (3) The height of the cylindrical portion in cylindrical weights shall be equal to the diameter.  
  (4) The weight of an iron shall not be below fifty grammes.

PART XX

INSPECTION

- Visiting trade premises                170. An assizer shall, at reasonable times, visit trade premises for the purpose of inspecting all weights and measures in use for trade.
- Obliteration of stamp                171.-(1) An assizer shall, upon inspection of a weight, measure or instrument, obliterate the stamp-  
  (a) on any weight, measure or instrument which cannot be stamped or re-stamped or comply with the requirements of the Act or these Regulations;  
  (b) on any repaired weight, measure, or instrument;  
  (c) on any weight, if the error in deficiency is more than half of the allowed in excess on verification, or if the error in excess is more than that allowed on verification;  
  (d) on a measure of length if the error in deficiency or excess exceeds four times the amount allowed on

*G.N. No. 229 (contd.)*

- verification;
- (e) on a measure of capacity other than an apothecaries measure, if the error in deficiency is more than half the allowed in excess on verification, or if the error in excess is more than that allowed on verification;
- (f) on an apothecaries measure if the error is greater than that allowed on verification;
- (g) on a weighing instrument if the error exceeds twice or if the deficiency in sensitiveness exceeds three times that allowed on verification;
- (h) on a liquid measuring pump if the error in deficiency is more than half that allowed in excess on verification, or if the error in excess is more than twice that allowed on verification.
- (2) An assizer may, upon inspection of liquid measuring pump, obliterate the stamp-
  - (a) on any liquid measuring pump of fixed type which has been erected or re-erected since it was last stamped.
  - (b) on any liquid measuring pump to which any alteration or addition has been made or which has been adjusted or repaired in any manner which might affect its accuracy since it was last stamped.

## PART XXI

### REPAIR OR MANUFACTURE OF MEASURING INSTRUMENTS OR SYSTEMS

Repairer and  
manufacturer  
to be licensed

- 172.-(1) Any person who intends to carry on the business of installing, servicing, overhauling or repairing any instrument shall apply for a licence to the Commissioner.
- (2) An application for a licence under this regulation shall be in writing and shall specify-
- (a) the name of the applicant and his proposed principal place of business and address;
  - (b) he has sufficient technical training or skill to carry out, the installation, service, overhaul or repair of the proposed instruments;
  - (c) the types of instruments which the applicant proposes to work on;
  - (d) the type of licence being applied for;
  - (e) he has at his disposal the tools, machinery or other

G.N. No. 229 (contd.)

resources necessary to carry out, the installation, service, overhaul or repair of the proposed instruments; and

- (f) any other particulars as the Commissioner may require;

Types of licenses and forms

173.-(1) A class "A" license shall be in the form prescribed in Form No. 1 of the Fifth Schedule to these Regulations and shall be granted to a person who is capable of working on all types of measuring instruments or systems.

(2) A class "B" license shall be in the form prescribed in Form No. 2 of the Fifth Schedule to these Regulations and shall be granted to a person who is capable of working on four to six types of specified measuring instruments or systems.

(3) A class "C" license shall be in the form prescribed in Form No. 3 of the Fifth Schedule to these Regulations and shall be granted to a person who is capable of working on two to three types of specified measuring instruments or systems.

(4) A class "D" license shall be in the form prescribed in Form No.4 of the Fifth Schedule to these Regulations and shall be granted to a person who is capable of working on at least two types of measuring instruments or systems.

(5) A class "E" license shall be in the form prescribed in Form No.5 of the Fifth Schedule to these Regulations and shall be granted to a person who:

- (a) is capable of manufacturing at least one type of measuring instruments or systems; and
- (b) submit the pattern together with technical drawings of the measuring instrument or system applied for to the Commissioner for approval.

Duration of licence and fees

174.-(1) Every license shall be valid for one year and shall be renewed for a further period not exceeding one year.

(2) There shall be paid in respect of every license or renewal of license, a fee corresponding to a class of instrument as shown in the Eighth Schedule to these Regulations.

Cancellation of licence

175.-(1) The Commissioner may, at any time, cancel any license if the licensee is convicted of an offence for a violation of any terms of his licence or contravention of these Regulations.

*Weights and Measures (General) Regulations*

---

G.N. No. 229 (contd.)

(2) A person who is aggrieved by the decision of the Commissioner in sub regulation (2) may appeal to the Minister and the decision of the Minister shall be final.

Licence to be displayed

176.-(1) A licensee shall display his licence at a conspicuous place at his principal place of business.

(2) A person who contravenes sub-regulation (1) commits an offence and upon conviction shall be liable to the penalty as provided for in the Act.

Where instruments or system may be repair

177. Any instrument may be serviced, overhauled or repaired:

- (a) the premises of the owner of measuring instrument or system;
- (b) at the place of business maintained by the licensee;
- or
- (c) on any other legally authorized premises.

Licensee to issue form

178.-(1) Where a licensee of Class A, B, C and D has installed, serviced, overhauled or repaired any instrument he shall issue to the owner of that instrument, a form prescribed in Form D in the First Schedule to these Regulations.

(2) Any person who contravenes sub-regulation (1) commits an offence and shall, on conviction, be liable to the penalty as provided for in the Act.

A licensee to maintain register

179.-(1) Every licensee of Class A, B, C and D shall maintain a register in which shall be entered the following particulars-

- (a) the type of measuring instrument or system and the name of the owner;
- (b) the nature of defect in the measuring instrument or system;
- (c) the nature of the work done by the licensee on the instrument or system; and
- (d) the date on which the licensee attended to the instrument or system.

(2) Any person who contravenes sub-regulation (1) commits an offence and shall, on conviction, be liable to a penalty as provided for in the Act.

*Weights and Measures (General) Regulations*

---

*G.N. No. 229 (contd.)*

Duty of licensee to submit documents, measuring instruments or system for inspection or verification

180.-(1) Every licensee shall cause every measuring instruments or systems manufactured, installed, overhauled, serviced or repaired by him to be examined by an assizer for the purposes of verification, stamping or certifying before the instrument or system is put to use.

(2) For the purposes of the examination of measuring instruments or systems under this Regulation, the licensee shall furnish an assizer with documents and register maintained pursuant to these Regulations and such other information as the assizer may require.

(3) The authorized person shall seal or re-seal measuring instruments or systems by means of a sealing plier constructed to impress upon every seal or sealing device such mark and number as the assizer may allot to him for the purpose of identification.

(4) A licensee of class "D" shall forward to an assizer a notice in writing in Form E as set out in the First Schedule to these Regulations, reporting every detail of such sealing or re sealing.

(5) Any user or repairer of the instrument shall, within twenty four hours of such sealing or re-sealing, send to an assizer a request in writing to verify the measuring instrument or system.

(6) A person who contravenes this regulation commits an offence and shall, on conviction, be liable to a penalty as provided for in the Act.

Verification of test weights and measures

181.-(1) Every test or standard weight or measures used by a licensee shall be submitted to an assizer not less than once every year for the purposes of verification.

(2) A licensee shall possess stamped testing measures of a pattern approved by an assizer and shall test each measuring instrument or system for accuracy before sealing or re-sealing.

(3) A person who contravenes this regulation commits an offence and shall, on conviction, be liable to a penalty as provided for in the Act.

Charges for verifications

182. The verification, prepackage testing, other charges and adjusting fees shall be as stipulated in the Sixth and Seventh

*G.N. No. 229 (contd.)*

and adjusting Schedules to these regulations respectively.  
fees

PART XXII

PRE-PACKED GOODS INSPECTIONS, TESTING, AND CERTIFICATION FEES

Mode of labeling 183. A producer or manufacturer of local goods or an importer, shall ensure that the goods are:  
(a) packed according to the requirements of the Act; and  
(b) if requiring labeling be labeled according to SADC MEL DOCUMENT 1 and OIML R 79 labeling requirements for pre-packed products as amended from time to time.

Powers to test and certify 184.-(1) Goods produced, manufactured or packed locally or otherwise shall be subject to inspection, testing and certification by the assizer at least once in every year.

(2) Every imported consignment shall be subject to inspection, testing and certification by Weights and Measures Inspector.

(3) After Identification of imported goods or consignment, an assizer shall seal or mark the container with a Government seal prior to inspection, testing and certification of such imported goods or consignment at the premises of the importer or any other place proposed by assizer.

Government fees and certification 185. Where after such inspection, testing and certification the goods are found to be within the prescribed limit of error or standards, an assizer or weights and measures inspector shall charge Government fees as prescribed in the Tenth Schedule to these Regulations and issue a Certificate of Conformity as prescribed in the Tenth Schedule to these Regulations.

Cancellation of a certificate of conformity GN No 536 of 1998 186.-(1) The Certificate of Conformity under these Regulations shall be issued on conformity to Weights and Measures (Packed Goods) Regulations.

(2) Where a person violates any of the conditions of the certificate of conformity, such certificate shall be revoked by issuance a certificate of conformity cancellation note as

G.N. No. 229 (contd.)

prescribed in the Twelveth Schedule to these Regulations.

Rejection  
Note  
G.N.No.536  
of 1998

187.-(1) Where after inspections and testing the goods are found not to comply with the requirements prescribed in the Weights and Measures (Packed Goods) Regulations 1998, a Rejection Note as prescribed in Twelveth Schedule to these Regulations, shall be issued.

(2) Where a rejection Note has been issued under sub-regulation (1), an assizer shall charge rejection fees double of the certification fees.

PART XXIII  
GENERAL PROVISIONS

Offence in  
relation to  
installment

188.-(1) A person shall, for gain or otherwise, not install a service, overhaul or conduct any repair on any measuring instrument or system except in accordance with a license issued by the Commissioner.

(2) A person who contravenes sub-regulation (1) commits an offence and shall, on conviction, be liable to the penalty provided for in the Act.

General  
Offence

189. A licensee who fails to comply with any obligation imposed on him under these Regulations commits an offence and shall on conviction, be liable to the penalty provided for in the Act.

Repeal of  
G.N. No 339  
of 1960 and  
G.N.NO 415  
of 2012

190.-(1) The Weights and Measures (General) Regulations 1960 is hereby repealed.

(2) Pre-packed Goods Inspections, Testing and Certification Fees Regulations, 2012 is hereby repealed.

Savings

191. Notwithstanding regulation 188, anything done or any action taken or purported to have been done or taken under the repealed Regulations shall be treated as if they have been done or taken under this Regulation.

*Weights and Measures (General) Regulations*

---

G.N. No. 229 (contd.)

FIRST SCHEDULE

FORMS

FORM A  
*(Regulation 3(4))*

FORM OF CERTIFICATE OF VERIFICATION OF SECONDARY STANDARDS

I HEREBY CERTIFY that the several secondary standards numbered viz. one each of .....have been this day duly verified and found to comply with the Act.

.....  
Number(s)

.....  
Warden of Secondary Standards  
Measures

.....  
Commissioner for Weights and  
Measures

Dated this ..... day of ....., year.....

FORM B  
*[Regulation 4(2)]*

FORM OF CERTIFICATE OF VERIFICATION OF WORKING STANDARDS

I HEREBY CERTIFY that the several working standards viz. .... have been this day duly compared by me and found to agree with the secondary standards.

Dated this ..... day of ....., year.....

.....  
Commissioner for Weights and Measures



*Weights and Measures (General) Regulations*

---

G.N. No. 229 (contd.)

FORM C

*(Regulation (16))*

FORM OF CERTIFICATE FOR THE USE, OR POSSESSION FOR USE IN TRADE, OF  
WEIGHTS, MEASURES OR WEIGHING OR MEASURING INSTRUMENTS NOT STAMPED  
WITH THE PRESCRIBED VERIFICATION MARK

This is to certify that ..... has been granted permission under section 35(2) of the Weights and Measures Act, to use or have in his possession for use in trade, the under-mentioned weight(s), measure(s), weighing or measuring instrument(s), which is/are not stamped with the prescribed verification mark.

Make and type of weight(s) or instrument(s).....

This certificate is valid until .....and is valid in the following areas of Mainland Tanzania.....

Conditions of issue .....

.....  
Commissioner for Weights and Measures

FORM D

*(Regulation 12(d) and 183 (1))*

FORM TO BE USED BY A LICENCEE AFTER SEALING OR RE-SEALING OF AN  
INSTRUMENT OR SYSTEM

Name of Licencee .....

I hereby certify that I have Erected/Installed/Overhauled/Serviced/Repaired the following instrument(s) or system(s)–

1. ....
2. ....
3. ....
4. ....

Owned by .....

Location .....

Date of sealing ....., year.....

Signature .....

Licencee.

To be submitted to the Commissioner for Weights and Measures within twenty four hours after completion of the work.

*Weights and Measures (General) Regulations*

---

G.N. No. 229 (contd.)

FORM E  
(Regulation 147(3) and 180(4))  
FORM OF LICENCE TO CONSTRUCT RAIL AND ROAD TANK

This licence is granted to ..... of  
..... and authorizing him to construct rail/road tank  
throughout Mainland Tanzania.

Licence number.....

Dated this ..... day of ..... year.....

.....  
Commissioner for Weights and Measures

FORM F  
(Regulation 146(d))  
CERTIFICATE OF VERIFICATION FOR VEHICLE TANKS

I certify that the under mentioned Vehicle Tank submitted to me by \_\_\_\_\_  
of \_\_\_\_\_ has this day been duly verified and has been stamped, having been  
found fit for use for trade/or has been rejected/or adjusted as indicated hereunder.

Specifications of Vehicle Tank

\_\_\_\_\_  
\_\_\_\_\_  
\_\_\_\_\_  
\_\_\_\_\_

Dated this \_\_\_\_\_ day of \_\_\_\_\_, year \_\_\_\_\_.

\_\_\_\_\_  
Commissioner for Weights and Measures

*Weights and Measures (General) Regulations*

---

G.N. No. 229 (contd.)

SECOND SCHEDULE

[Regulation 21(4)]

SHAPE SIZES FOR WEIGHTS WITH LESS THAN 1g

Nominal value (mg)	Polygonal sheets	wires		
			or	
5, 50, 500	Pentagon	Pentagon		5 segments
2, 20, 200	Square	Square		2 segments
1, 10, 100, 1,000	Triangle	Triangle		1 segment

THIRD SCHEDULE

(Regulation 21(4))

DIFFERENT SHAPES OF WEIGHTS

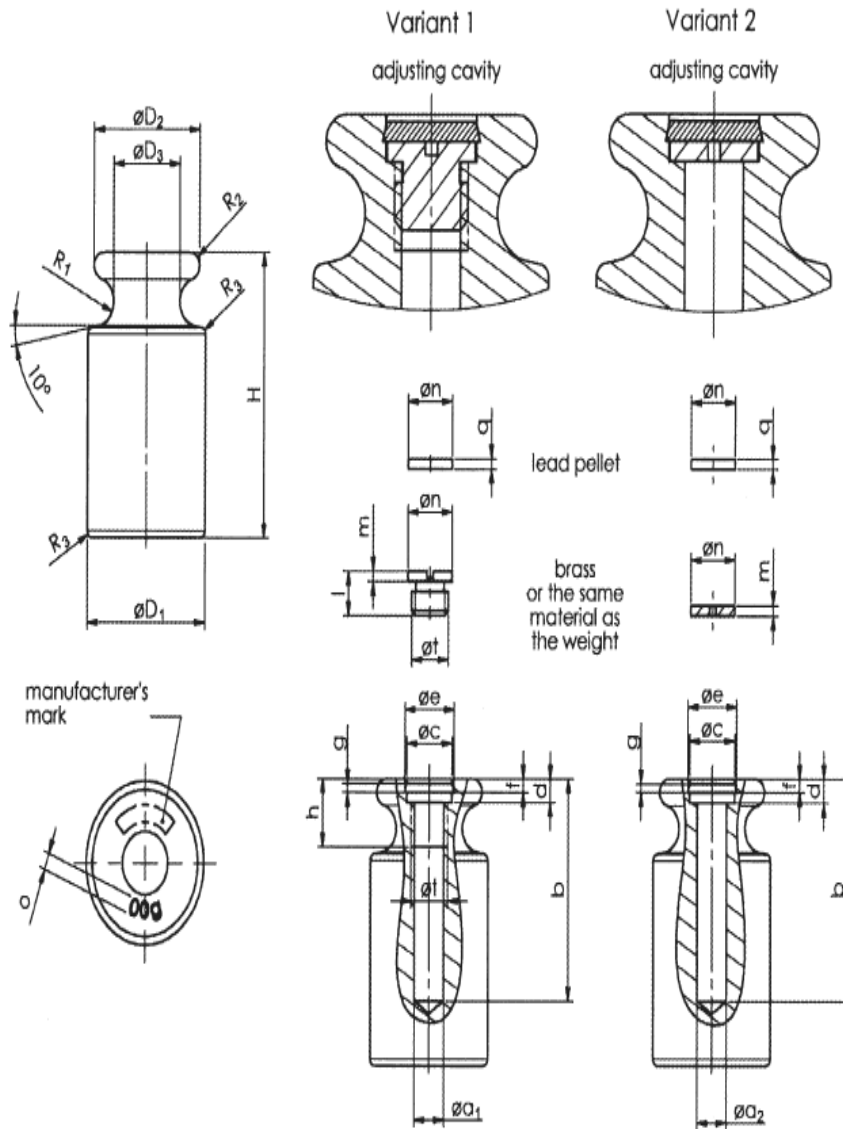

*Weights and Measures (General) Regulations*

---

G.N. No. 229 (contd.)

FOURTH SCHEDULE

TABLE I

*[Regulation 22]*

WEIGHTS FOR USE WITH WEIGHING INSTRUMENTS  
OF ACCURACY CLASS III AND IIII

Nominal value (kg)	MPE (mg)	Nominal value (g)	MPE (mg)
5000	2 500 000	500	250
2000	1 000 000	200	100
1000	500 000	100	50
500	250 000	50	30
200	100 000	20	25
100	50 000	10	20
50	25 000	5	16
20	10 000	2	12
10	5 000	1	10
5	2 500		
2	1 000		
1	500		

TABLE II  
*(Regulation 27)*

MEASURES OF LENGTH

Denomination (m)	Limits of Error	
	End Measurement (+ or -) mm	Line Measurement (+ or -) mm
0.5	1	0.5
1	1	0.7
1.5	2	1
2	2	1
3	2	2
4	-	2
5	-	2
10	-	4
15	-	6
20	-	8
25	-	10
30	-	11
50	-	18
60	-	22
100	-	36

*Weights and Measures (General) Regulations*

---

G.N. No. 229 (contd.)

TABLE III  
(Regulation 43)

MEASURES OF CAPACITY

Capacity of measure	Limit of Error (+ or -)
50 ml	2
100 ml	3
200 ml	5
250 ml	5
500 ml	10
1 L	10
2 L	20
5 L	50
10 L	50
20 L or More	0.5 percent

TABLE IV  
Maximum Permissible error on initial verification for Electronic Measuring Instruments  
(Regulation 73)

Maximum permissible errors	For loads, $m$ , expressed in verification scale intervals, $e$			
	CLASS I	CLASS II	CLASS III	CLASS III
$\pm 0.5 e$	$0 \leq m \leq 50\ 000$	$0 \leq m \leq 5\ 000$	$0 \leq m \leq 500$	$0 \leq m \leq 50$
$\pm 1.0 e$	$50\ 000 < m \leq 200\ 000$	$5\ 000 < m \leq 20\ 000$	$500 < m \leq 2\ 000$	$50 < m \leq 200$
$\pm 1.5 e$	$200\ 000 < m$	$20\ 000 < m \leq 100\ 000$	$2\ 000 < m \leq 10\ 000$	$200 < m \leq 1\ 000$

TABLE V  
BEAM SCALES  
(Regulation 75(1)(a))

Class A		
Capacity of Instrument	Sensitiveness when fully loaded (mg)	Greatest error allowed when Fully loaded (mg)
2 g	0.02	0.04
5 g	0.05	0.10
10 g	0.10	0.20
20 g	0.20	0.40
50 g	0.50	1
100 g	1	2
200 g	2	4

*Weights and Measures (General) Regulations*

---

G.N. No. 229 (contd.)

500 g	5	10
1 kg	10	20
2 kg	20	40
5 kg	30	60
10 kg	50	100
20 kg	100	200
50 kg	200	400

TABLE VI

BEAM SCALES  
(Regulation 75(1)(b))

Class B		
Capacity of Instrument	Sensitiveness when fully loaded	Greatest error allowed when Fully loaded
2 g	1 mg	2 mg
5 g	2 mg	4 mg
10 g	3 mg	6 mg
20 g	5 mg	10 mg
50 g	10 mg	20 mg
100 g	20 mg	40 mg
200 g	30 mg	60 mg
500 g	50 mg	100 mg
1 kg	100 mg	200 mg
2 kg	200 mg	400 mg
5 kg	300 mg	600 mg
10 kg	500 mg	1 g
20 kg	1 g	2g
50 kg	2 g	4 g
100 kg	5 g	10 g
200 kg	10 g	20 g

TABLE VII

BEAM SCALES

CLASS C

(Regulation 75(1)(c))

Capacity of Instrument	Sensitiveness when fully loaded	Greatest error allowed when Fully loaded
------------------------	---------------------------------	--

*Weights and Measures (General) Regulations*

---

G.N. No. 229 (contd.)

100 g	100 mg	200 mg
500 g	500 mg	1 g
1 kg	1 g	2 g
5 kg	3 g	6 g
10 kg	5 g	10 g
20 kg	10 g	20 g
50 kg	15 g	30 g
100 kg	25 g	50 g
200 kg	50 g	100 g
500 kg	100 g	200 g
1000 kg	150 g	300 g

TABLE VIII

COUNTER MACHINES  
(Regulation 89)

Capacity of Instrument	Sensitiveness when fully loaded (g)	Greatest error allowed when Fully loaded (g)
500 g	1.5	2.2
1 kg	2.0	3.0
2 kg	3.0	4.5
3 kg	4.0	6.0
5 kg	6.0	9.0
10 kg	7.0	10.5
15 kg	8.0	12.0
20 kg	9.0	13.5
25 kg	10.0	15.0
30 kg	11.0	20.0
50 kg	15.0	30.0

TABLE IX

PLATFORM MACHINES, DEAD-WEIGHT MACHINES AND WEIGHBRIDGES  
(Regulation 118)

Capacity of Instrument	Vibrating machines		Accelerating machines
	Sensitiveness when fully loaded	Greatest error when loaded	Greatest error when loaded
50 kg	15 g	30 g	30 g
100 kg	20 g	50 g	50 g
150 kg	30 g	60 g	60 g
200 kg	40 g	70 g	70 g
250 kg	45 g	80 g	80 g
300 kg	50 g	90 g	90 g



*Weights and Measures (General) Regulations*

---

G.N. No. 229 (contd.)

500 kg	70 g	120 g	120 g
1000 kg	100 g	200 g	200 g
1500 kg	120 g	250 g	250 g
2000 kg	150 g	300 g	300 g
5 tons	1500 g	2000 g	2000 g
10 tons	2000 g	3000 g	3000 g
20 tons	3000 g	4000 g	4000 g
25 tons	3500 g	5000 g	5000 g
30 tons	3500 g	5500 g	5500 g
40 tons	4000 g	7000 g	7000 g
50 tons	5000 g	8000 g	8000 g
80 tons	7000 g	9000 g	9000 g
100 tons	8000 g	10000 g	10000 g

TABLE X  
AUTOMATIC MACHINES  
(Regulation 128)

Use	Capacity	Error
Weighing small loads of tea, coffee, etc.	20 g and upwards	1/2% of the load in excess only
Weighing grain, etc.	5 kg and upwards	1/4% of the load in excess or deficiency
Weighing coal, etc.	50 kg and upwards	1/2% of the load in excess or deficiency
Totalizing machines	500 kg and upwards	1/2% of the total load of 30 loads in excess or deficiency

TABLE XI  
SELF-INDICATING WEIGHING INSTRUMENTS  
(Regulation 134)

Capacity of Instrument	Permissible error (g)
Under 1 kg	2
1 kg and under 5 kg	5
5 kg and under 10 kg	6
10 kg and under 15 kg	10
15 kg and under 30 kg	15
30 kg and under 50 kg	20
50 kg and under 75 kg	30

*Weights and Measures (General) Regulations*

---

G.N. No. 229 (contd.)

For capacities exceeding 75 kg the error shall not exceed the weight corresponding to one-half of the interval between consecutive graduations on the dial or chart.

TABLE XII

LIQUID MEASUREMENT PUMPS  
*(Regulation 166(1))*

Capacity of measure	Maximum permissible Errors	
	When new or After Repair (+) ml	On Verification or Inspection (+ or -) ml
250 ml	5	5
500 ml	10	10
1 L	10	10
2 L	20	20
5 L	50	50
10 L	50	50
20 L or More	0.5 percent	0.5 percent

TABLE XIII

METRIC CARAT WEIGHTS  
*(Regulation 171)*

Denomination (Metric Carat)	Weight in Grams	Error in excess only (mg)
500	100	6
200	40	6
100	20	4
50	10	4
20	4	2
10	2	2
5	1	1
2	0.4	1
1	0.2	1
0.5	0.1	1

*Weights and Measures (General) Regulations*

---

G.N. No. 229 (contd.)

FIFTH SCHEDULE

LICENCES  
Form No. 1  
UNITED REPUBLIC OF TANZANIA  
WEIGHTS AND MEASURES AGENCY  
MEASURING INSTRUMENTS/SYSTEMS LICENCE  
CLASS "A"  
(Regulation 177 (2))

No. LA 000000

This licence is granted to .....  
of.....  
and authorizes him/her to install, overhaul, service or repair all types of measuring instruments or systems throughout the Mainland Tanzania:-

This licence is valid until..... Date of issue:.....

.....  
Commissioner for Weights And Measures

Form No. 2  
UNITED REPUBLIC OF TANZANIA  
WEIGHTS AND MEASURES AGENCY  
MEASURING INSTRUMENTS/SYSTEM LICENCE  
CLASS "B"  
(Regulation 177 (3))

No. LB 000000

This licence is granted to.....  
of.....and authorizes him/her to install, overhaul, service or repair not more than six and not less than four types of measuring instruments or systems throughout the Mainland Tanzania:-

1. ....  
....
2. ....  
....
3. ....  
....
4. ....  
....
5. ....  
....
6. ....

This licence is valid until..... Date of issue:.....

.....  
Commissioner for Weights And Measu

*Weights and Measures (General) Regulations*

---

G.N. No. 229 (contd.)

Form No. 3  
UNITED REPUBLIC OF TANZANIA  
WEIGHTS AND MEASURES AGENCY  
MEASURING INSTRUMENTS/SYSTEMS LICENCE  
CLASS "C"  
(Regulation 177 (4))

No. LC 000000

This licence is granted to .....  
of ..... and authorizes him/her to  
install, overhaul, service or repair not more than three types of measuring instruments or systems  
throughout the Mainland Tanzania:-

1. ....
2. ....
3. ....
4. ....

This licence is valid until ..... Date of issue: .....

.....  
Commissioner For Weights And Measures

Form No. 4  
THE UNITED REPUBLIC OF TANZANIA  
WEIGHTS AND MEASURES AGENCY  
MEASURING INSTRUMENTS/ SYSTEMS LICENCE  
CLASS "D"  
[Regulation 177 (5)]

No. LD 000000

This licence is granted to .....of ..... and authorizes  
him/her to erect, install, overhaul, adjust, service or repair measuring instruments or systems listed  
hereunder throughout the Mainland Tanzania:-

1. ....
2. ....
3. ....

This licence is valid until ..... Date of issue: .....

.....  
Commissioner for Weights And Measures

*Weights and Measures (General) Regulations*

---

G.N. No. 229 (contd.)

Form No. 5  
THE UNITED REPUBLIC OF TANZANIA  
WEIGHTS AND MEASURES AGENCY  
MEASURING INSTRUMENTS/SYSTEMS LICENCE  
CLASS "E"  
*[Regulation 177 (6)]*

No. LE 000000

This licence is granted to ..... of ..... and authorizes him/her to manufacture the following type(s) of measuring instrument(s) or systems listed hereunder throughout the Mainland Tanzania:-

1. ....
2. ....
3. ....
4. ....
5. ....

This licence is valid until ..... Date of issue.....

.....  
Commissioner for Weights and Measures

*Weights and Measures (General) Regulations*

---

G.N. No. 229 (contd.)

SIXTH SCHEDULE

*[Made under regulation 186]*

VERIFICATION, PREPACKAGE TESTING AND OTHER CHARGEABLE FEES

1. Measurement of length for each measure:
  - (a) not exceeding 500 millimetres ..... 2,000/-
  - (b) exceeding 500 millimetres and not exceeding 5metre..... 5,000/-
  - (c) exceeding 5 metre ..... 15,000/-
  
2. Measures of capacity:
  - A.
    - (i) Un-subdivided measures of capacity used for direct selling of goods to customer:
      - (a) not exceeding 250 millilitres ..... 500/-
      - (b) exceeding 250 millilitres but not exceeding 2 litres ..... 1000/-
      - (c) exceeding 2 litres but not exceeding 5 litres ..... 2000/-
      - (d) exceeding 5 litres but not exceeding 10 litres ..... 4,000/-
      - (e) exceeding 10 litres but not exceeding 20 litres ..... 6,000/-
      - (f) exceeding 20 litres but not exceeding 50 litres ..... 10,000/-
      - (g) exceeding 50 litres but not exceeding 100 litres ..... 20,000/-
      - (h) exceeding 100 litres but not exceeding 500 litres ..... 30,000/-
      - (i) exceeding 500 litres but not exceeding 1000 litres ..... 60,000/-
      - (j) exceeding 1000 litres but not exceeding 2000 litres ..... 100,000/-
      - (k) exceeding 2000 litres but not exceeding 5000 litres ..... 160,000/-
      - (l) exceeding 5000 litres but not exceeding 10000 litres ..... 240,000/-
      - (m) exceeding 10,000 litres ..... 300,000/-
  
    - (ii) Un-subdivided measures of capacity used for verifying measures of capacity (eg. check pumps) in 2A(i):
      - (a) not exceeding 250 millilitres ..... 2,000/-
      - (b) exceeding 250 millilitres but not exceeding 1 litre ..... 3,000/-
      - (c) exceeding 1 litre but not exceeding 5 litres ..... 5,000/-
      - (d) exceeding 5 litres but not exceeding 10 litres ..... 14,000/-
      - (e) exceeding 10 litres but not exceeding 20 litres ..... 20,000/-
      - (f) exceeding 20 litres but not exceeding 50 litres ..... 30,000/-
      - (g) exceeding 50 litres but not exceeding 100 litres ..... 40,000/-
      - (h) exceeding 100 litres but not exceeding 200 litres ..... 50,000/-
      - (i) exceeding 200 litres but not exceeding 500 litres ..... 100,000/-
      - (j) exceeding 500 litres but not exceeding 1000 litres ..... 200,000/-
      - (k) exceeding 1000 litres ..... 300,000/-

B.

*Weights and Measures (General) Regulations*

---

G.N. No. 229 (contd.)

- (i) Sub-divided measures of capacity used for direct selling of goods to customers:

Fees chargeable shall be those applicable to similar un-subdivided measures plus in 2A (i) 50% of that rate.

- (ii) Sub-divided measure of capacity for verifying measures in 2B(i):

Fees chargeable shall be those applicable to similar un-subdivided measures in 2A (ii) plus 50% of that rate.

3. Instruments-

(A) instruments for the measurement of liquid fuel and lubrication oil and alike:

- a) Petrol Pump.....75,000/-
- b) Twin container ..... 50,000/-
- c) Flow metres as verified or calibrated quarterly or after repair 500,000/-
- d) Verification of fuel/oil unloading bulk flow meter (from ship tank) at port or other places.....2,500,000/-

(B) metrological supervision fee to terminals for monitoring measurements and inspecting measuring system or instruments during offloading/discharging of bulk oil/fuel from the ship tanker to final receiving tank farms per standard litre at 20 °C is Tshs. 1/- or at a rate as determined from time to time by EWURA or any other authorized institution.

4. Weights:

(i). Verification fees for lower class (M3 for each weight ;)

	DENOMINATION	FEEES
(a)	not exceeding 100 g	500/-
(b)	not exceeding 100g but not exceeding 500 g	1000/-
(c)	Exceeding 500g but not exceeding 2kg	1500/-
(d)	Exceeding 2kg but not exceeding 5kg	2000/-
(e)	Exceeding 5kg but not exceeding 50kg	15,000/-
(f)	Exceeding 50kg but not exceeding 200kg	20,000/-
(g)	Exceeding 200kg but not exceeding 500kg	30,000/-
(h)	Exceeding 500 kg	100,000/-

(ii) Verification fees for higher class (M2 and above for each weight ;)

	DENOMINATION	FEEES
(a)	Not exceeding 50 g	9,000/-
(b)	Exceeding 50 g but not exceeding 200 g	7,500/-
(c)	Exceeding 200 g but not exceeding 500 g	6,000/-
(d)	Exceeding 500 g but not exceeding 1 kg	9,000/-
(e)	Exceeding 1 kg but not exceeding 5 kg	15,000/-
(f)	Exceeding 5 kg but not exceeding 20 kg	20,000/-
(g)	Exceeding 20 kg	25,000/-

*Weights and Measures (General) Regulations*

G.N. No. 229 (contd.)

iii) Verification fees for Metric Carat Weight:

	DENOMINATION	FEES
(a)	Not exceeding 0.5 C.M	15,000/-
(b)	Exceeding 0.5 C.M but not exceeding 20 C.M	12,000/-
(c)	Exceeding 20 C.M but not exceeding 500 C.M	9,000/-
(d)	Exceeding 500 C.M	6,000/-

5. Verification fees for weighing instruments (Class III and IIII):

	DENOMINATION	FEES
(a)	not exceeding 5kg	7,000/-
(b)	exceeding 5kg but not exceeding 10kg	7,000/-
(c)	exceeding 10 kg but not exceeding 20kg	7,000/-
(d)	exceeding 20 kg but not exceeding 50kg	10,000/-
(e)	exceeding 50 kg but not exceeding 100kg	20,000/-
(f)	exceeding 100kg but not exceeding 200 kg	30,000/-
(g)	exceeding 200kg but not exceeding 300 kg	40,000/-
(h)	exceeding 300kg but not exceeding 500 kg	50,000/-
(i)	exceeding 500kg but not exceeding 2000 kg	60,000/-
(j)	exceeding 2000 kg but not exceeding 5000 kg	150,000/-
(k)	exceeding 5000kg but not exceeding 10000 kg	175,000/-
(l)	exceeding 10000kg but not exceeding 30000 kg	200,000/-
(m)	exceeding 30000kg but not exceeding 50000 kg	300,000/-
(n)	exceeding 50000kg but not exceeding 100000 kg	500,000/-
(o)	exceeding 100000kg but not exceeding 200000 kg	700,000/-
(p)	exceeding 200000 kg	800,000/-

NOTE

- i. Weighing instruments of higher class (I and II) shall be chargeable 100% extra fees of the rate stated in item 5.
  - ii. Weighing instruments stated in item 5 (a),(b),(c) and (d) plus numbers of weights not exceeding one set and adjustment if needed shall be charged Tshs. 7,000/- in total, irrespective of their capacities
  - iii. One set of weights means and include 50 g, 100 g, 200 g, 500 g, 1 kg, 2 kg and 5 kg.
6. Pattern or type approval each instruments of lower class shall be 500% the fees chargeable for certification of such measuring instrument categorically.  
NB: 50% of the above fees shall be chargeable in addition for higher class instrument.
  7. Verification of vehicle, lorries and alike for carrying sand and other ballast (each).....15,000/- per cubic metre
  8. Verification of railway tank, skid tanks, road tank, ship tank and the like for each one litre of capacity.....15/- per litre.
  9. Verification of tyre pressure gauge, quarterly...(each)t .....10,000/-
  10. Verification of thermometer;
    - (a) laboratory and clinical thermometer.....each.....20,000/=
    - (b) production and in stores thermometer.....each.....25,000/=
  11. Verification on utility meter (gas, electrical, water and alike) .....10,000/=



*Weights and Measures (General) Regulations*

---

G.N. No. 229 (contd.)

12. Testing fees 50% of the prescribed verification or certification fees for a rejected instrument shall be chargeable.
13. Measuring instrument used for buying or selling precious stones shall be chargeable 500% fee of the rates stated in items 5 above.
14. Measuring instrument used in laboratories and pharmaceuticals shall be chargeable 300% fee of the rates stated in items 5 above.
15. Hiring out test weight of 500 kg per day, .....each .....10,000/=
16. Hiring out proving tank per day.....each.....100,000/=
17. Consultancy fee for legal metrology issues/matters is negotiable between the Agency and particular consumer(s)/Client(s)/Customer(s).
18. (a) Verification fees for initial 100,000 litres of a fixed storage tank ....10/= per litre and 70 cents per each litre increased thereafter  
 (b) certification fees for the initial 100,000 litres of a fixed storage tank.....5/= per litre and 50 cents per each litre increased thereafter.  
 (c) Verification fees for fixed storage tanks below 100,000 litres .....50/= per litre  
 (d) certification fees for fixed storage tanks below 100,000 litres .....30/= per litre  
 (e) fees for a rejected fixed storage tank on subsequent testing shall be 50% of the corresponding certification fees.

SEVENTH SCHEDULE

ADJUSTING FEES  
(Regulation 186)

1. Measures of capacity for each measure	50% of the prescribed stamping/certification fees for the particular measures.
2. Instruments for measuring liquid fuel and lubricating oil for each instrument	100% of the prescribed stamping/certification fees for the particular instrument.
3. Weights: For each weight	50% of the prescribed stamping/certification fees for the particular weight.
4. Weighing instruments	The fee chargeable for each instrument exceeding 50 kg shall be at the rate of the prescribed verification fees for that particular weighing instrument.

*Weights and Measures (General) Regulations*

---

G.N. No. 229 (contd.)

EIGHTH SCHEDULE

APPLICATION, LICENCE AND MISCELLANEOUS FEES  
(Regulation 178(2))

1. Application fees (Tshs.)
  - (a) For repair of weighing instrument .....50,000/= for Tanzanian citizens and 200,000/= for non-citizen.
  - (b) For repair of liquid measuring instruments.....50,000/= for Tanzanian citizens and 200,000/= for non-citizen.
  - (c) For other weights and measures practitioners.....50,000/= for Tanzanian citizens and 200,000/= for non-citizen.
  - (d) Cargo declaration form.....10,000/=
2. Licence fees (Tshs.)
  - (a) Class A Licence (All weighing instruments).....100,000/=
  - (b) Class B Licence 6 types and not less than 4 types.....75,000/=
  - (c) Class C Licence 4 types and not less than 2 types.....50,000/=
  - (d) Class B Licence for repair of measuring instruments.....250,000/=
  - (e) Class E Licence for measuring instrument manufacturing.....300,000/=
  - (f) Tank construction Licence.....800,000/=
  - (g) Fixed storage tank Verification Licence.....400,000/=
3. Miscellaneous fees:
  - (a) Affixing solder studs (each) ..... 5,000/=
  - (b) Denominating a metal measure (each) ..... 5,000/=
  - (c) Denominating a metal measure (each) ..... 5,000/=
  - (d) Balancing a weighing instrument (each) ..... 1,500/=
  - (e) Cleaning/dusting of weighing (or measuring instrument)(each) 50% to the prescribed verification fees
  - (f) Inserting of plug (each) ..... 2,000/=
  - (g) Cleaning of dipstick (each) ..... 5,000/=
  - (h) Retyping of Verification sticker ..... 20,000/=
  - (i) Transfer of readings on another dipstick (each) .... 15,000/=
  - (j) Approval of vehicle tank/ railway wagon Verification 10% of paid Verification fees status or document from another country of such mark or document
  - (k) Where any weight, measure, weighing or measuring instrument not intended for trade use has been examined, tested and/or verified by an assizer, a fee chargeable shall be equal to 50% of the prescribed stamping fee on a similar instrument.

*Weights and Measures (General) Regulations*

---

G.N. No. 229 (contd.)

- (l) Any other service rendered 10% of prescribed fee
- (m) Certification of automatic filler, packer, weigher, measure and alike. (each).

FILLING/ PACKING OUTLETS	FEES
1 to 5	150,000/=
6 to 20	200,000/=
21 to 50	250,000/=
51 to 80	600,000/=
81 to 100	800,000/=
Exceeding 100	1,000,000/=

- (n) Where an Assizer is delayed in the conduct of a test through negligence or failure on the part of a person submitting any weight, measure, weighing or measuring instrument for verification or where he is delayed awaiting minor adjustment to be made by a repairer, the Assizer shall charge a fee at the rate equal to the verification fee for that weight, measure, weighing or measuring instrument per hour so delayed with proportional part of an hour, so delayed.

NINTH SCHEDULE

FEES  
[Regulation 189]

1. For goods manufactured/ produced/made or packed in Mainland Tanzania, fees shall be charged as follows:

Category	Lot size	Sampling	No. of product denomination	Fees
Goods manufactured/ produced/made or packed in Mainland Tanzania	0-100	100%	Each	30,000/-
	101-500	50	Each	100,000/-
	501-3200	80	Each	200,000/-
	3201 and above	125	1-5 Each	300,000/-
			6-10 Each	200,000/-
			11 and above, each	100,000/-

2. For purpose of charging fees, all items which are above 50g or 50ml but not exceeding 200g or 200ml, shall be compounded to form single package approximately or equal to 1000g or 1000ml as single package for purpose of determining lot size.
3. For imported goods, fees shall be 0.2% of F.O.B of imported goods or Tanzania shillings 100,000 whichever is higher.

*Weights and Measures (General) Regulations*

---

G.N. No. 229 (contd.)

TENTH SCHEDULE

[Regulation 189]

C/N: 0000001

The United Republic of Tanzania  
The Weights and Measures Agency



CERTIFICATE OF CONFORMITY OF PRE-PACKED GOODS

Name of Weights and Measures Inspector.....

I hereby certify that I have this day inspected and/ tested the under-mentioned goods/products:

Belonging to..... Of.....

Tel..... Bill of lading No.....

This .....day of.....20.....

Signature.....

The validity of this Certificate is one year.

Regional Manager's name:.....

Signature: .....

Date: .....

*NB. This certificate is issued on conformity to the Weights and Measures (Packed Goods) Regulation 1998 and it shall be revoked in case of violation.*



*Weights and Measures (General) Regulations*

---

G.N. No. 229 (contd.)

**TWELVETH SCHEDULE**

*[Regulation 191(1)]*

R/N: 0000001

The United Republic of Tanzania  
The Weights and Measures Agency



**PRE-PACKAGED GOODS REJECTION NOTE**

To.....  
Of.....  
Tel.....  
Bill of lading No.....

I,.....being an Assizer of Weights and Measures do hereby certify that I have rejected the under mentioned goods/products for non-conformity to Weights and Measures (Packed Goods) Regulations.

This .....day of.....20.....

Signature.....

Dar es Salaam  
..... 2016

CHARLES JOHN MWIJAGE  
*Minister for Industry,  
Trade and Investment*